ALGEBRA II:
A
Survey of Functions

JEFF SHRINER

\boxed{JS}

CREATED FOR UNIVERSITY OF COLORADO PCDP, SUMMER 2014

CONTENTS

0	§0.1: PRE-REQUISITE REVIEW	5
0	§0.2: FUNCTIONS	7
0	§0.3: INVERSE FUNCTIONS	11
0	§0.4: TRANSFORMING FUNCTIONS	15
1	§1.1: LINEAR FUNCTIONS	19
1	§1.2: QUADRATIC FUNCTIONS	23
1	§1.3: EXPONENTIAL FUNCTIONS	27
1	§1.4: LOGARITHMIC FUNCTIONS	31
1	§1.5: TRIGONOMETRIC FUNCTIONS	33
1	§1.6: POLYNOMIAL FUNCTIONS	37
1	§1.7: RATIONAL FUNCTIONS	41
	APPENDIX	45
A	GROUP WORK	47
B	HOMEWORK	85
C	QUIZZES	93
D	EXAMS	103

O

§0.1: PRE-REQUISITE REVIEW

You are expected to be very familiar with

1. Basic arithmetic
2. Rules of exponents
3. The coordinate $(x - y)$ plane
4. Manipulating expressions involving variables

We will review these topics quickly for one day. I assume that you have some familiarity with

1. Solving linear equations with one variable
2. Linear functions
3. Quadratic functions

These topics are included in the sections that we will cover this semester.

O

§0.2: FUNCTIONS

A very simple description of the purpose of algebra is to be able to describe the outside world using mathematical symbols, so that we may manipulate and analyze these symbols in order to draw conclusions about a particular situation.

For example, suppose you own a business that makes skateboards. You notice that there is a relationship between the number of skateboards you make, and the amount of money you earn (i.e., your profit). If you had the ability to write the relationship between production and profit down *mathematically*, then you could answer many important questions about your business, namely, 'How many skateboards should I produce to maximize my profit?', that you would not be able to answer without a mathematical description of your business.

The main tool that allows us to describe our surroundings mathematically is a *function*. In general, this is the main task of our course this semester: to create, manipulate, and analyze functions in order to answer questions about relationships in our world.

WHAT IS A FUNCTION?

Definition. A *function* is a rule that relates two quantities, call them x and y , with the property that each input (a value for x) is related to *exactly* one output (a value for y). We say that the quantity y is a function of the quantity x .

Intuitively, a function is best thought of as a machine: a function f is a machine that receives one input, x , and spits out exactly one output y which is associated to x :

$$x \rightarrow \boxed{f} \rightarrow y$$

Compare this to the following diagram, which does *not* represent a function:

$$x \rightarrow \boxed{f} \begin{matrix} \rightarrow y \\ \rightarrow z \end{matrix}$$

§0.2: FUNCTIONS

Q1. Briefly describe why the last diagram does not fit the definition of a function.

Example. Height (the y value) is a function of students in this class (the x value). If you give the function a student's name (an x value), there is *exactly* one height associated to that student:

$$\text{Jim} \rightarrow \boxed{f} \rightarrow 5' 10''$$

Q2. Think of another relationship which is a function. Can you think of a relationship which is *not* a function?

THE RULE OF FOUR

There are four main ways that we can represent functions:

1. Graphically
2. Numerically (using tables)
3. Equations
4. Words

These different representations are known as *the Rule of Four*. One representation is often better than another to answer certain questions, so it is important that we are able to convert a table representation to a graph, a graph to an equation, words to a graph, etc.

Q3. Convert the following table to a graph:

x	0	1	2	3
y	-1	0	3	4

FUNCTION NOTATION

A function as an equation might look something like $y = 3x + 2$. This equation tells you exactly what the function does: if you input 1, you multiply it by 3 then add 2, giving you 5. That is, under this function

relationship, the input 1 is associated to the output 5.

Remember our machine analogy of functions from above? There is a way to write function equations that is more in line with the machine analogy, and we call this *function notation*. Instead of writing a function as $y = 3x + 2$, we would write it in function notation as $f(x) = 3x + 2$. Think of the $f()$ as the machine - it takes in x values, and spits out y values. So using our example from above, we could write $f(1) = 5$.

Q4. Suppose a function f is defined by $f(x) = x^2 + 2$. Find $f(2)$. Is 2 an x -value or a y -value? Is $f(2)$ an x -value or a y -value?

DOMAIN AND RANGE

Two very important properties of a function are its *domain* and *range*.

Definition. The *domain* of a function is the set of all possible input values the function may take. The *range* of a function is the set of all possible output values a function may return.

We should always keep the Rule of Four in our minds when approaching questions, and domain/range questions are no exception. For example, if I asked you the range of the function $y = x^2$, it would be beneficial to know that the graph of this function looks like this:

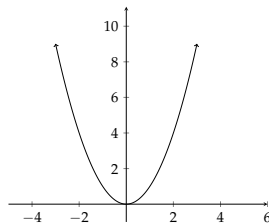

Looking at the graph, we can visually see that the range is $[0, \infty)$, since this function achieves every non-negative y -value, and does not achieve any negative y -values.

Most functions we will see will have a domain of all real numbers; this means the function can take in any x -value, and will return exactly one y -value. There are a couple of algebraic rules which we already know about that can prevent a function from having a domain of all real numbers:

§0.2: FUNCTIONS

1. We cannot divide a non-zero number by 0; for example, $\frac{1}{0}$ is undefined.
2. We cannot take the square root (or any even root) of a negative number; for example, $\sqrt{-1}$ is undefined.

We'll add to this list as we learn about new functions.

Q5. Sketch the graph of a function whose range is $[-2, 5]$.

Q6. Consider the function $f(x) = \frac{6}{x-5}$. What is the domain of f ?

O

§0.3: INVERSE FUNCTIONS

Let's return to our skateboard business example. Suppose we have a function f whose input is number of skateboards produced, and whose output is profit. For example, if $f(10) = 200$, this means if we produce 10 skateboards, we will make a profit of \$200. This function is beneficial to answer questions such as 'If I make 30 skateboards, what will my profit be?'. We simply input 30 into our function f , and it spits out the answer.

But what if we asked a slightly different question: 'If my goal is to make \$500 in profit, how many skateboards should I make?'. Our function f isn't quite as helpful in answering this question, since we're starting with the *output* (\$500), and asking about what the *input* should be to achieve this output. When we re-phrase questions this way, we're asking questions about the *inverse function* of f .

WHAT IS AN INVERSE?

Intuitively, the inverse function of a function f just means switching the input and output of the function f . In our example above, the function f has input of number of skateboards, and output of profit. The inverse function of f would have input of profit, and output of number of skateboards (which is why the inverse function would help us answer the question of how many skateboards we need to produce to make \$500). As the name suggests, an inverse function is a *function*. This means it must have exactly one output for every input. We will see that not every function has an inverse function. If a function f has an inverse function, we say f is *invertible*.

Definition. If a function f is invertible, we denote its inverse function by f^{-1} . Using this notation,

$$f^{-1}(y) = x \quad \text{means} \quad f(x) = y.$$

TESTING INVERTIBILITY

Recall that we have an easy test to determine if a graph represents a function; it's called the *vertical line test*. If any vertical line intersects

§0.3: INVERSE FUNCTIONS

the graph in more than one point, the graph is not a function; otherwise, it is a function.

Q1. Briefly explain why the vertical line test works.

There is a similar test to determine if a function has an inverse function, and it works for the same reason the vertical line test works. It is called the *horizontal line test*. If any horizontal line intersects the graph in more than one point, the function *does not* have an inverse function; otherwise, it does have an inverse function.

Q2. Indicate next to each graph whether the function has an inverse function.

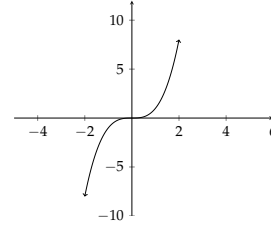
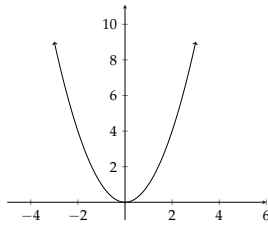

INVERSES GRAPHICALLY

Because an inverse function is just the original function with domain and range swapped, it is easy to predict what the graph of the inverse function f^{-1} looks like, given the graph of the original function f :

We obtain the graph of f^{-1} by reflecting the graph of f over the line $y = x$.

Example.

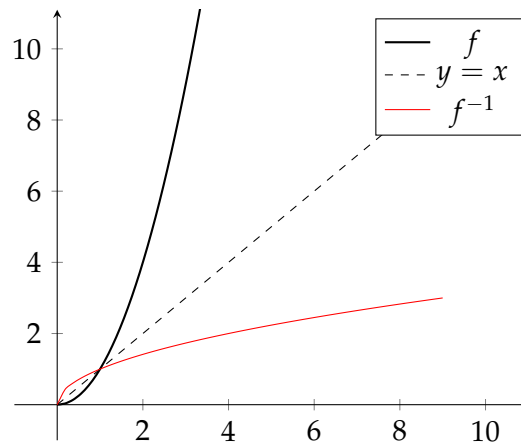

INVERSES ALGEBRAICALLY

The definition of an inverse function also gives us insight into how to find the equation of the inverse function. Algebraically, swapping domain and range means swapping 'x' and 'y'. So if we want the equation of a function's inverse, we swap x and y and then solve for y .

Example. The function $y = 2x + 4$ is invertible. To find the inverse function, we first swap x and y to obtain

$$x = 2y + 4.$$

Then solving for y , we get

$$y = \frac{1}{2}x - 2.$$

So if $f(x) = 2x + 4$, we found that $f^{-1}(x) = \frac{1}{2}x - 2$.

Q3. The function $f(x) = x^3 + 2$ is invertible. Find $f^{-1}(x)$.

COMPOSITE FUNCTIONS

Composing two functions means plugging one function in as the input of another function. For example, if $f(x) = x + 2$ and $g(x) = x^2 + 6$, then f composed with g is

$$f(g(x)) = g(x) + 2 = (x^2 + 6) + 2 = x^2 + 8.$$

Wherever we see the variable x in the function $f(x)$, we replace it with the function $g(x)$.

Q4. With f and g defined as above, find g composed with f .

$$g(f(x)) =$$

One of the reasons we care about composite functions is that it gives us a way to test whether two functions are inverses of each other:

If $f(g(x)) = x$ and $g(f(x)) = x$, then g and f are inverse functions.

Q5. Using composite functions, verify that $f(x) = 2x + 4$ and $g(x) = \frac{1}{2}x - 2$ are inverses of each other.

O

§0.4: TRANSFORMING FUNCTIONS

As previously mentioned, functions can be used to model our surroundings. For example, the shape of the following graph could be a good model for a falling object, where the x -axis measures time (in seconds) and the y -axis measures the height (in feet) of the object from the ground:

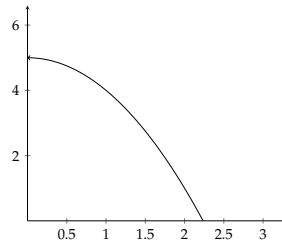

In this case, the object is dropped from an initial height of 5 feet, and hits the ground just after 2 seconds. The shape is a good model for a falling object - but what if we wanted to change some of the specifics, like the initial height the object is dropped from, or the amount of time it takes the object to hit the ground? We'd like to transform the given function to meet specific criteria, without changing its general shape. There are three main transformations we can perform on a function to accomplish this: shifts, stretches/compressions, and reflections. We'll explore how to perform these transformations algebraically in this section.

SHIFTS

To *shift* a graph literally means to move each point of the graph a certain number of units up/down or right/left. If you shift a graph up/down, we call it a *vertical shift*. If you shift a graph left/right, we call it a *horizontal shift*. For example, shifting the graph of x^2 vertically 2 units looks like this:

§0.4: TRANSFORMING FUNCTIONS

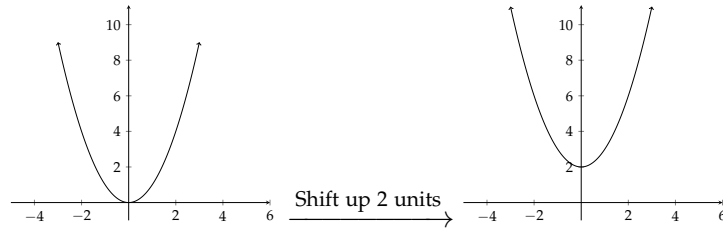

Which coordinates are changing when we make a vertical shift, the x or y values? The y -values are changing, so in order to make a vertical shift algebraically, we should change y -values. Recall that in function notation, $f(x)$ represents the y -value associated to the input x , so to shift $f(x)$ vertically, we should *add* a constant to $f(x)$:

The expression $f(x) + c$ is the vertical shift of $f(x)$ c units, where the shift is up if c is positive, and down if c is negative.

Changes to y -values are referred to as an *outside change*, since we're changing the function outside of the machine f . For example, the first graph above has the form $f(x) = x^2$, so the equation of the second graph (which is a vertical shift up by 2 units) is $f(x) + 2 = x^2 + 2$.

Similarly, if we were to shift x^2 right or left, it's now the x -values that are changing. So in order to make a horizontal shift algebraically, we should should change x -values:

The expression $f(x + c)$ is the horizontal shift of $f(x)$ c units, where the shift is left if c is positive, and right if c is negative.

Changes to x -values are referred to as an *inside change*, since we're changing the function inside of the machine f . For example, if we wanted to shift $f(x) = x^2$ right 2 units, we would write $f(x - 2) = (x - 2)^2$.

Q1. Sketch the graph of the transformation of x^2 which is a vertical shift down 2 units and a horizontal shift right 1 unit. Then write the equation of this transformation.

STRETCHES/COMPRESSIONS

In this course we will only discuss vertical stretches and compressions. Visually, a *stretch* just means you're taking the graph by the edges and stretching it out:

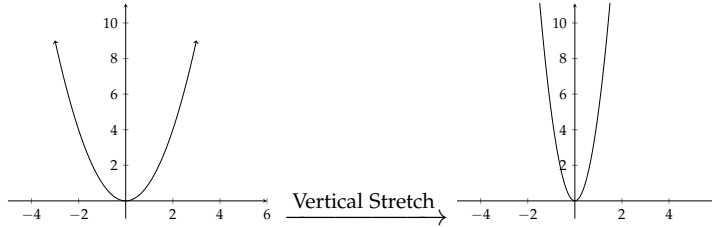

A *compression* means you are taking the graph by the ends and compressing (pushing) them together:

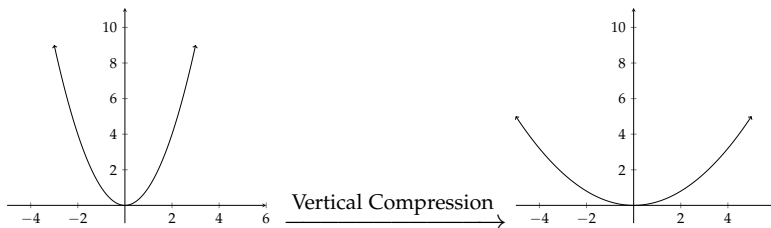

In both cases, we're changing y -values, so again we expect this to be an *outside* change:

The expression $cf(x)$ is a vertical stretch/compression of $f(x)$. It is a stretch if $c > 1$, and a compression if $0 < c < 1$.

Q2. Describe in words what each of the following transformations does to the graph of $f(x)$:

1. $5f(x)$
2. $\frac{1}{3}f(x)$
3. $2f(x) + 1$

REFLECTIONS

Finally, we may reflect a graph vertically (across the x -axis), or horizontally (across the y -axis). Here is the vertical reflection of x^2 :

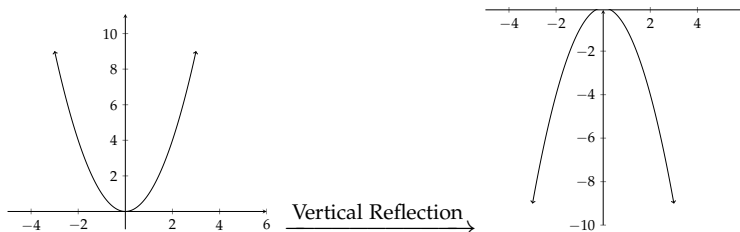

Q3. What does the horizontal reflection of x^2 look like?

A vertical reflection changes y -values (so is an outside change), and a horizontal reflection changes x -values (so is an inside change). We have the following algebraic description of reflections:

The expression $-f(x)$ is a vertical reflection of $f(x)$. The expression $f(-x)$ is a horizontal reflection of $f(x)$.

Q4. The function $g(x) = -(x - 2)^2 + 3$ is a transformation of x^2 . Describe the transformation in words, then try to sketch the graph of the transformation. Use a graphing utility to compare your sketch to the real graph.

 §1.1: LINEAR FUNCTIONS

We now begin our exploration of some of the most important families of functions. The first on our list is the simplest type of function, a *linear function*.

Imagine that you have a paper route, and you get paid \$100 per month no matter how many papers you deliver. You also get paid \$5 per house that you deliver a paper to. With this information, you can calculate how much you will make in a month if you deliver x papers; that is, the amount of money you make in a month is a function of the number of papers you deliver (why?). For every extra paper you deliver, you earn \$5 additional dollars; that is, for every increase in one unit of your input, your output increases by 5. The fact that this increase is a constant number is what characterizes linear functions. In fact, if y is the amount you make in a month and x is the number of papers you deliver, the linear function that represents this scenario is $y = 5x + 100$ (verify that this makes sense by checking a few different values of x).

RATE OF CHANGE

Intuitively, the *rate of change* between two points is a measure of how the function is changing between those two points. Graphically, it's the slope of the line connecting the two points:

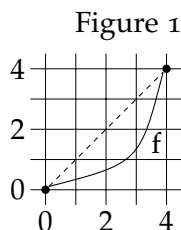

The following definition tells us how to calculate the rate of change between two points.

Definition. The *rate of change* between a point (x_1, y_1) and a point (x_2, y_2) is the number

$$m = \frac{y_2 - y_1}{x_2 - x_1}.$$

§1.1: LINEAR FUNCTIONS

It is often denoted by $\frac{\Delta y}{\Delta x}$ (change in y over change in x), and a useful mnemonic for remembering this is ‘rise over run’.

Q1. Calculate the rate of change between the two points in Figure 1 above.

A *linear function* is a function in which any two points have a constant rate of change.

POINT-SLOPE FORM

Because any two points have a constant rate of change (the line connecting any two points has constant slope), a point and a slope completely determined a line. That is, if you want a line that goes through the point (x_1, y_1) and has slope m , there is only one line that can do this! To see what the equation of this line is, if (x, y) is any other point on the line, we know the rate of change between (x_1, y_1) and (x, y) must be m :

$$\frac{y - y_1}{x - x_1} = m.$$

Multiplying both sides by $x - x_1$ we get

$$y - y_1 = m(x - x_1).$$

This is the equation of a line, and is known as *point-slope form*.

Example. The equation of the line which goes through the point $(1, 5)$ with slope 2 is $y - 5 = 2(x - 1)$.

SLOPE-INTERCEPT FORM

The equation of a line in point-slope form doesn’t look like the equation of functions that we’re used to seeing. We can, however, convert any line in point-slope form to a more familiar form.

Example. Consider the line $y - 5 = 2(x - 1)$. We can solve for y to write $y = 2(x - 1) + 5$, and then distribute the 2 and simplify to obtain

$$y = 2x + 3.$$

The equation $y = 2x + 3$ represents the same line as $y = 2(x - 1) + 5$, it’s just written in a different form. This new form is called *slope-intercept form*, and is more generally represented as

$$y = mx + b,$$

where m is the *slope* of the line, and b is the *y-intercept* of the line (where the line crosses the y -axis).

Q2. Write the equation of the line that passes through the point $(-1, 2)$ and has slope 3. What is the y -intercept of this line?

RULE OF FOUR

Whenever we introduce new functions, you should always ask yourself what these functions look like in terms of the Rule of Four.

Graphically: The graphs of linear functions are straight lines. Try to imagine what different lines might look like, depending on their slope and y -intercept. Here are a few:

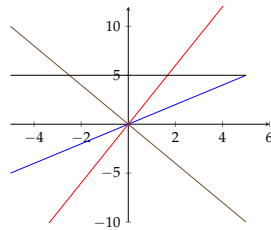

Q3. Match the following equations to their graphs in the figure above:

$$(i) y = 3x \quad (ii) y = 5 \quad (iii) y = -2x \quad (iv) y = x$$

Numerically: A table of values can only represent a linear function if every two points in the table have a constant rate of change. For example, the table

x	0	1	2	3
y	2	4	6	8

represents a linear function.

Q4. Verify that the above table is linear, and find the slope of the line that it represents.

Equation: We have already seen that a line can be represented in point-slope form, $y - y_1 = m(x - x_1)$, or in slope-intercept form, $y = mx + b$.

Words: Since a constant rate of change is what characterizes linear functions, any description in words of such a function must somehow indicate a constant rate of change. Re-read the paper route scenario from the beginning of this section; the description that we are paid \$5 per house that we deliver to is describing the constant rate of change of our output (money earned) with respect to our input (houses delivered to).

INCREASING / DECREASING FUNCTIONS

Definition. A function is *increasing* if its y -values increase as the x values increase. A function is *decreasing* if its y -values decrease as the x -values increase.

Intuitively, we see whether a graph is increasing/decreasing by looking at what the y -values do as we move along the graph from left to right. For example, linear functions with positive slope are *increasing*, while linear functions with negative slope are *decreasing*.

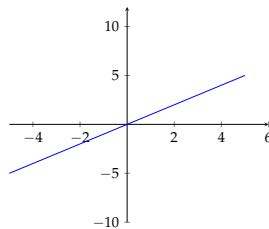

Increasing

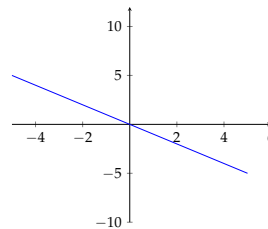

Decreasing

Increasing and decreasing are properties of functions in general, not just linear functions. For example, $f(x) = x^2$ is decreasing on $(-\infty, 0)$, and increasing on $(0, \infty)$ (sketch the graph of x^2 to verify this).

Q5. Sketch a graph that is increasing on $(-\infty, -1)$, decreasing on $(-1, 3)$, and increasing on $(3, \infty)$.

§1.2: QUADRATIC FUNCTIONS

The simplest quadratic function is $f(x) = x^2$, which we have already seen. Any other quadratic function is just a transformation of x^2 , so here are some examples of graphs of a few other quadratic functions:

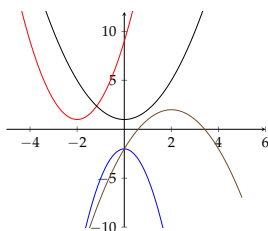

Since they are all transformations of x^2 , they all have the same general shape. We call this shape a *parabola*. There are some key characteristics of parabolas that we'll be interested in:

1. The y -intercept
2. The vertex (this is the 'peak' of the parabola)
3. The zeros (these are the x values whose associated y -values are $y = 0$; i.e., where the parabola crosses the x -axis)

Like linear functions, we can write quadratic functions in more than one form. Each form highlights a different characteristic, so we'd like to be able to convert quadratic equations between the different forms.

STANDARD FORM

The standard form a quadratic function is

$$f(x) = ax^2 + bx + c,$$

where a , b , and c are constants. Recall that the y -intercept of a graph is the y -value when $x = 0$, so standard form is good for seeing the y -intercept of a parabola: plugging in $x = 0$ into the standard form equation, we get $y = c$, so c is the y -intercept. The sign of the constant a also tells us whether the parabola opens up (if $a > 0$) or down (if $a < 0$).

Q1. Consider the quadratic function $f(x) = -x^2 + 2x + 3$. What is the y -intercept of this graph? Does the parabola open up or down?

§1.2: QUADRATIC FUNCTIONS

FACTORED FORM

The factored form of a quadratic function is

$$f(x) = a(x - r)(x - s),$$

where $a, r,$ and s are constants. What is the value of $f(r)$? If I plug in $x = r,$ I get

$$f(r) = a(r - r)(r - s) = a \cdot 0 \cdot (r - s) = 0.$$

That is, $x = r$ is a *zero* of this quadratic function. Similarly, $x = s$ is a zero. Thus, factored form is good for seeing the zeros of a parabola. Again, the constant a also tells us whether the parabola opens up (if $a > 0$) or down (if $a < 0$).

Q2. Consider the quadratic function $g(x) = 2(x - 2)(x + 5)$. What are the zeros of this parabola? Does the parabola open up or down?

Notice that we can use multiplication to write

$$g(x) = 2(x - 2)(x + 5) = 2(x^2 + 3x - 10) = 2x^2 + 6x - 20.$$

Now $g(x)$ is in standard form. This is an example of converting a quadratic function from one form to another.

VERTEX FORM

The vertex form of a quadratic function is

$$f(x) = a(x - t)^2 + k,$$

where $a, t,$ and k are constants. It turns out that the point (t, k) is the vertex of the parabola, so this form is good for finding the vertex. As in the last two cases, the constant a tells us whether the parabola opens up or down. Pay close attention to the negative sign in front of the t in vertex form. This means that the quadratic $f(x) = (x - 2)^2 + 1$ has vertex $(2, 1)$, while the quadratic $g(x) = (x + 2)^2 - 1$ has vertex $(-2, -1)$.

FINDING ZEROS

As mentioned above, one of the main characteristics we'd like to know about a parabola is its zeros. There are three different ways we can complete this task:

Factor: This means taking a quadratic function in standard form, and re-writing it in factored form. It is essentially reversing the FOIL process in your head. Let's walk through an example. Consider the quadratic $h(x) = x^2 + x - 6$. I'd like to write h so that it has the form $h(x) = (x - r)(x - s)$, so I need two numbers that multiply to -6 , and add to 1 . Thinking about this for a moment, we should notice that 3 and -2 do just this, so we can write $h(x) = (x - 2)(x + 3)$ (FOIL this back out and verify we get $h(x) = x^2 + x - 6$). Once we've done this, it's easy to see that the zeros of h are $x = 2$ and $x = -3$. *Note that not all quadratics factor.*

Completing the Square: This means taking a quadratic function in standard form, and re-writing it in vertex form. This has the added benefit that we'll also be able to see the vertex of the parabola, and also works on more quadratics than factoring does. Here is how the process works:

1. Start with your quadratic in standard form: $x^2 + 2x - 3$
2. Divide your ' b ' term by 2 , and then square it: $2/2 = 1$, and $1^2 = 1$
3. Add the number you get from part (2) and then take it away again: $(x^2 + 2x + 1) - 1 - 3$
4. The quadratic in parentheses is now a perfect square:

$$(x + 1)^2 - 1 - 3$$

5. Simplifying, we now have our quadratic in vertex form:

$$(x + 1)^2 - 4$$

This process will take some practice to get used to, and we'll get to some more complicated examples in class. But let's remember our original goal: to find the zeros of $x^2 + 2x - 3$. We've found that $x^2 + 2x - 3 = (x + 1)^2 - 4$. So we want to find when $(x + 1)^2 - 4 = 0$, which is true when $(x + 1)^2 = 4$, which means $x + 1 = \pm\sqrt{4}$, which means $x = -1 \pm \sqrt{4}$. Hence, $x = 1$ and $x = -3$.

Quadratic Formula: This is a formula that will tell you the zeros of any quadratic function in standard form. If you start with $ax^2 + bx + c$, the quadratic formula tells us that the zeros are

$$x = \frac{-b \pm \sqrt{b^2 - 4ac}}{2a}.$$

Q3. Find the zeros of the quadratic $f(x) = x^2 + 3x - 4$ using all three of the methods discussed above: by factoring, by completing the square, and by using the quadratic formula. (Note: You should get the same answers under each method.)

Thought Exercise: In the examples we've done, we've only seen parabolas that have exactly 2 zeros. Is it possible for a parabola to have no zeros? Is it possible for a parabola to have exactly 1 zero? Is it possible for a parabola to have more than 2 zeros? Think about what a zero looks like graphically, and draw some pictures of different parabolas to convince yourself. How would each of these scenarios be displayed in the quadratic formula?

§1.3: EXPONENTIAL FUNCTIONS

Suppose you put \$100 into a bank account that earns 10% interest annually. This means that at the end of one year, the bank gives you 10% of what's in your account; in this case, that would be $.10 \times 100$, which is \$10, so you would now have \$110. At the end of the second year, you would earn 10% of what's in your account again. This time, it would be $.10 \times 110$, which is \$11, so you would now have \$121.

As you can see, there is a relationship between the number of years we let our money sit in the bank account and the amount of money that we have; in fact, the amount of money we have is a function of time (why?). Also, from our calculations above, we can see that there is a pattern in this relationship. Namely, after each year (one unit increase in time), our money increases by a constant *percent*. This constant percent change is what characterizes exponential functions (contrast this with linear functions, which have a constant rate of change).

EXPONENTIAL GROWTH

Let's look at the calculations from our example above a bit closer. At the end of the first year, the total amount of money that we have is 110% of what we originally had. That is, to find out how much money we have after the first year, we can multiply $\$100 * 1.10 = \110 . After year two, the total amount that we have is again 110% of what we had after year one. That is, to find out how much money we have after the second year, we can multiply $\$110 * 1.10 = \121 . You can repeat this for year three, four, etc., and notice that each time you're multiplying by the constant factor of 1.10. In other words, if you want to know how much money we'll have after t years, you could compute $100 \times (1.10)^t$ (\$100 is what we start with, and we multiply this by the factor 1.10 t times).

Definition. If $b > 1$, a function of the form $f(t) = ab^t$ is called *exponential growth*. The number a is the *initial quantity*, b is the *growth factor*, and $b - 1$ is the *growth rate* (as a decimal).

Q1. Consider the function $f(t) = 20 \cdot 1.25^t$. What is the initial quantity? What is the growth factor? What is the growth rate?

The graph of an exponential growth function looks like this:

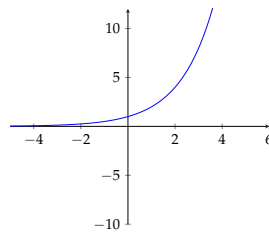

EXPONENTIAL DECAY

Exponential decay is similar to exponential growth, with the exception that the quantity *decreases* at a constant percent instead of *increases* at a constant percent. Consider the scenario in which someone takes a 100 mg tablet of aspirin, and the body decomposes the aspirin by 10% each hour. At the end of the first hour, how much aspirin will be in the body? Saying that the body decomposes 10% is the same as saying there is 90% of the original amount left, so we could calculate $100 \text{ mg} \times .90 = 90 \text{ mg}$. After the second hour, we would do the same: $90 \text{ mg} \times .90 = 81 \text{ mg}$. Again, we see that if we want to know how many mg are left in the body after t hours, we could calculate $100 \times .90^t$.

Definition. If $0 < b < 1$, a function of the form $f(t) = ab^t$ is called *exponential decay*. The number a is the *initial quantity*, b is the *decay factor*, and $1 - b$ is the *decay rate* (as a decimal).

Q2. Consider the function $g(t) = 80 \cdot .80^t$. What is the initial quantity. What is the decay factor? What is the decay rate?

The graph of an exponential decay function looks like this:

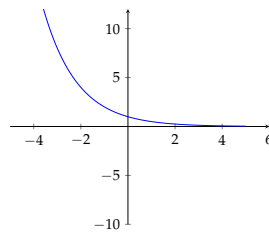

CONTINUOUS GROWTH/DECAY

Definition. An exponential function of the form $f(t) = ae^{kt}$ is called *continuous growth/decay*. The number a is the *initial quantity* and k is the *continuous growth/decay rate* (as a decimal). If $k > 0$, this is *continuous growth*. If $k < 0$, this is *continuous decay*.

Remark: These are indeed exponential functions, where $e^k = b$:

$$f(t) = ae^{kt} = a(e^k)^t = ab^t.$$

Q3. Consider the function $f(t) = 4e^{-2t}$. What is the initial quantity? Is this continuous growth or decay? What is the growth/decay rate?

FINDING EQUATIONS OF EXPONENTIALS

Given information about an exponential relationship, we need to be able to write down the equation of the function that represents that relationship. Since an exponential function has the form $f(t) = ab^t$, we need only find the values of a and b to determine what the exponential function is.

Example. We will find the equation of the exponential function which passes through the points $(2, 18)$ and $(3, 54)$. Since I know these points are both a part of the same exponential relationship, I can write

$$18 = ab^2 \text{ and } 54 = ab^3.$$

The trick is to take advantage of the fact that the initial quantity is the same no matter what the input is; we do this by taking a ratio:

$$\frac{54}{18} = \frac{ab^3}{ab^2} = \frac{b^3}{b^2} = b.$$

Thus, we have found that $b = 3$. Finally, we can use either equation to solve for a :

$$18 = a(3)^2 \Rightarrow a = \frac{18}{3^2} = 2.$$

Hence, the equation for the exponential function passing through these two points is $f(t) = 2 \cdot 3^t$.

Q4. Find the equation of the exponential function passing through the points $(1, 12)$ and $(2, 48)$.

§1.4: LOGARITHMIC FUNCTIONS

Let's return to our first example of an exponential relationship, in which we've invested \$100 in a bank account which earns 10% annually. Then after t years, the amount of money we have in our account is given by $A(t) = 100(1.10)^t$. But suppose we asked a slightly different question: how many years will it take for us to have \$1,000 in our account? Since \$1,000 is an output of our function relationship, answering this question means solving

$$1,000 = 100(1.10)^t$$

for the variable t . Up to this point, we don't have a way algebraically to get a variable out of the exponent. Logarithms are the solution to this problem.

WHAT IS A LOGARITHM?

Consider an exponential function with initial quantity 1 and base $b > 0$, $f(x) = b^x$. Recall that the graphs of exponential functions pass the horizontal line test, and are therefore invertible. We call the inverse function of $f(x) = b^x$ the *logarithm of base b* . With our knowledge of what inverse functions are (input and output are swapped), we have the following definition:

Definition. The function $g(x) = \log_b(x)$ is called the *logarithm of base b* , where

$$\log_b(x) = y \text{ means } b^y = x.$$

Remark: The most common bases are 10 and e . Instead of $\log_{10}(x)$ we just write $\log(x)$ (which is called the *common logarithm*), and instead of $\log_e(x)$ we just write $\ln(x)$ (which is called the *natural logarithm*).

Q1. Use the definition of logarithm to find

1. $\log(100) =$

2. $\log_2(8) =$

3. $\log_4(64) =$

Q2. Recalling what the domain and range of exponential functions are, what do you think the domain and range of logarithms are? What do you think the graph looks like?

PROPERTIES OF LOGARITHMS

Because logarithms are inverses of exponentials, they have some nice properties, which may look similar to some rules of exponents that you know. For any two positive constants A and B and base b , the most important properties of logarithms are

1. $\log_b(AB) = \log_b(A) + \log_b(B)$
2. $\log_b\left(\frac{A}{B}\right) = \log_b(A) - \log_b(B)$
3. $\log_b(A^x) = x\log_b(A)$
4. $\log_b(b^x) = x$
5. $b^{\log_b(x)} = x$

Notice that property (3) was our motivation for logarithms - if I have the equality $5^x = 10$, I can get the variable x out of the exponent by taking the log of both sides:

$$x \log(5) = \log(10),$$

which implies $x = \frac{\log(10)}{\log(5)} = \frac{1}{\log(5)}$.

Suppose you want to simplify $\log(5 \cdot 2^x)$. It might be tempting to apply property (3) right away and write $x \log(5 \cdot 2)$, but *this is incorrect!* It is subtle, but property (3) only works when *everything* inside the logarithm is raised to the exponent. In our example, only the 2 is raised to the exponent x (and not the 5), so we must first apply property (1) and write $\log(5) + \log(2^x)$, then we can write $\log(5) + x \log(2)$.

Q3. Use logarithms to solve $1,000 = 100(1.10)^t$ for t .

 §1.5: TRIGONOMETRIC FUNCTIONS

We know that there is a relationship between the time of year and the average temperature in Colorado. The average temperature on December 21 is much lower than the average temperature on July 21. In fact, the average temperature in Colorado is a function of the number of days since January 1 (why?). How would we describe this relationship? As time increases from January 1, the average temperature likely rises, eventually reaching a maximum sometime in the Summer, then begins to decrease, eventually reaching a minimum sometime in the Winter. Then when 365 days have passed, it repeats the cycle once again. So far, it would be difficult to model this function relationship with any of the functions we've talked about so far. To model this type of scenario, we need a function that repeats itself over and over again. Trigonometric functions provide this property.

RADIANS VS. DEGREES

The input of trigonometric functions is often thought of as an angle. Up to this point, you are likely used to talking about angles in the unit of 'degrees': 180 degrees is a straight line, while 360 degrees is a circle. There is, however, a different unit for angles that is more commonly used in pre-calculus and calculus. This unit is called a *radian*, and it has the following relationship with degrees:

$$2\pi \text{ radians} = 360 \text{ degrees.}$$

Using this relationship, here is a table of the most common angles:

Degrees	Radians
0	0
90	$\frac{\pi}{2}$
180	π
270	$\frac{3\pi}{2}$
360	2π

Unless otherwise specified, you should assume units of radians when we're talking about angles.

Q1. How many radians is 45 degrees? 60 degrees? 30 degrees?

§1.5: TRIGONOMETRIC FUNCTIONS

$\sin(x)$, $\cos(x)$, AND $\tan(x)$

In order to define the most basic trigonometric functions, we need the *unit circle* - the circle of radius 1 centered at the point $(0, 0)$:

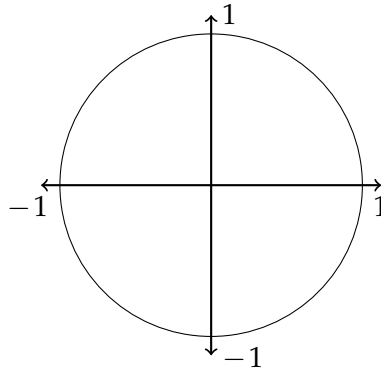

The input of trig functions are angles around the unit circle, which is why the outputs eventually start repeating (0 radians is the same as 2π radians is the same as 4π radians, etc.). For an angle t , we first draw a line segment in the unit circle which has that angle:

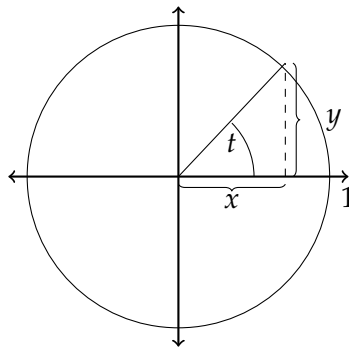

We then define the following trigonometric functions:

Definition. The *trigonometric functions* $\sin(t)$, $\cos(t)$, and $\tan(t)$ are defined based on the above unit circle as follows:

$$\sin(t) = y \quad \text{i.e., opposite over hypotenuse}$$

$$\cos(t) = x \quad \text{i.e., adjacent over hypotenuse}$$

$$\tan(t) = \frac{y}{x} \quad \text{i.e., opposite over adjacent}$$

Q2. Using the definition of these functions, complete the following table, where t is in radians:

t	$\sin(t)$	$\cos(t)$	$\tan(t)$
0			
$\frac{\pi}{2}$			
π			
$\frac{3\pi}{2}$			
2π			

You should know these main values for each of the trigonometric functions. In pre-calculus, you'll learn a few more. If you plot your points for each function and connect the dots, you should get that the graphs for these functions look something like this:

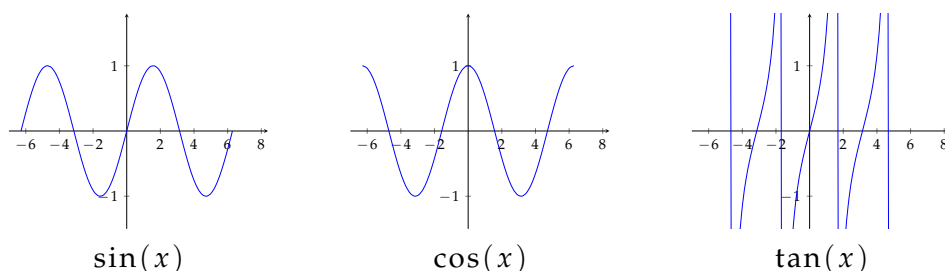

Note: The vertical lines in the graph of $\tan(x)$ denote x -values for which the function is not defined.

EVEN/ODD FUNCTIONS

We can describe a function's symmetry as *even*, *odd*, or *neither*, and trigonometric functions provide a great example of this symmetry. Intuitively, you should think of symmetry in terms of graphs. *Even symmetry* means a graph is symmetric about the y -axis (you can fold it along the y -axis evenly). The graph of $\cos(x)$ is an example of even symmetry, as is the graph of x^2 .

Odd symmetry means a graph is symmetric about the origin (the point $(0,0)$), which means you can fold a graph over the y -axis then over the x -axis evenly. The graph of $\sin(x)$ is an example of odd symmetry, as is the graph of x^3 .

Q3. Is the graph of $\tan(x)$ even or odd?

It is important to have a picture in your head of what this symmetry looks like, but it is also possible to describe this symmetry algebraically. Here is how we define the symmetries we've described above using function notation:

Definition. 1. A function $f(x)$ is *even* if $f(-x) = f(x)$.

2. A function $f(x)$ is *odd* if $f(-x) = -f(x)$.

Note that according to this definition, $f(x) = x^2$ is in fact even since

$$f(-x) = (-x)^2 = x^2 = f(x).$$

Also, $g(x) = x^3$ is odd since

$$g(-x) = (-x)^3 = -x^3 = -g(x).$$

Note that it is possible for functions to have *neither* symmetry. An example is $h(x) = x + 3$, since $h(-x) = -x + 3$ is neither $h(x)$ nor $h(-x)$ (it is also easy to look at the graph of $h(x)$ and see visually that there is no symmetry).

Q4. Determine algebraically whether each of the following functions are even, odd, or neither. Then verify your answers by looking at the graph of each function.

1. $f(x) = x^4 - x^2$

2. $g(x) = x^3 + x$

3. $h(x) = x^4 + x^3$

 §1.6: POLYNOMIAL FUNCTIONS

Polynomials are arguably the most useful and flexible class of functions that have discussed up to this point. To define them, we first need to know about *power functions*.

POWER FUNCTIONS

A *power function* has the form $f(x) = kx^p$, where k and p are constants. We are already familiar with the power functions x^2 and x^3 . Using our knowledge of transformations, we know the general shape of every power function that has an integer power p :

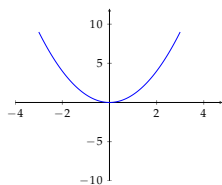
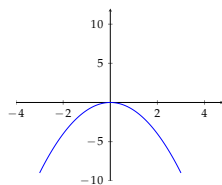
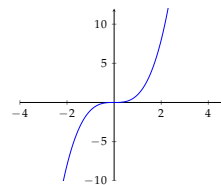
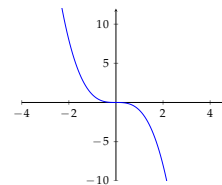
 p even, $k > 0$  p even, $k < 0$  p odd, $k > 0$  p odd, $k < 0$

Remembering these graphs will be helpful in our study of polynomial functions.

Q2. Sketch the general shape of the graph of $f(x) = -2x^7$.

STANDARD FORM

A *polynomial function in standard form* is a sum of power functions whose powers are non-negative integers. Here are some examples of polynomials:

1. $p(x) = x^2$
2. $p(x) = x^2 + x$
3. $p(x) = -5x^3 + 3x + 4$
4. $p(x) = 3x^{10} + 4x^4 - 2x^2 - x + 1$

Here are some examples of functions that are *not* polynomials:

1. $f(x) = x^2 + x^{-1}$ (x^{-1} has a negative power)
2. $f(x) = x^4 + 2x + \sqrt{x}$ ($\sqrt{x} = x^{\frac{1}{2}}$ has a fractional power)

We need some terminology in order to describe polynomials.

Definition. The highest powered term of a polynomial is called the *leading term*. The power of the leading term is called the *degree of the polynomial*, and the coefficient of the leading term is called the *leading coefficient*.

Example. Consider the polynomial $p(x) = -2x^5 + 3x^2 + 2x + 1$. The leading term is $-2x^5$, the degree of the polynomial is 5, and the leading coefficient is -2 .

The leading term of a polynomial determines some important properties of a the graph of the polynomial, so it will be important to be able to identify this term.

Q2. Let $p(x) = 10x^8 + 3x^7 + 5x^5 - 2x^3 + 4$. What is the leading term? What is the degree of $p(x)$? What is the leading coefficient?

FACTORED FORM

One of our goals is given the equation of a polynomial, we would like to be able to sketch its graph. In order to do this somewhat accurately, we need to know the zeros of the polynomial (where it crosses the x -axis). Do you recall what form of a quadratic function showed us the zeros of a parabola? It was *factored form*, and the same is true for general polynomials.

For example, the function $p(x) = 5(x + 2)^2(x - 3)^3(x - 5)$ is a polynomial in factored form (if you were to multiply all of these terms out, you would have the polynomial in standard form). The factored form of this polynomial easily shows us that its zeros are at $x = -2$, $x = 3$, and $x = 5$.

As mentioned above, the leading term of a polynomial is a very important term in determining the properties of a polynomial, so it's important that we can identify this term, even for polynomials written in factored form. You don't actually have to multiply everything out in order to determine the leading term from factored form. Here's an example to illustrate how this is done.

Example. Let $p(x) = 5(x + 2)^2(x - 3)^3(x - 5)$. In order to determine the degree of the polynomial, we only need to count what the highest powered term would be if we multiplied everything out. The $(x + 2)^2$ would give us an x^2 term, the $(x - 3)^3$ would give us an x^3 term, and the $(x - 5)$ would give us an x term. Multiplying these highest degree terms together would give us $x^2 \cdot x^3 \cdot x = x^6$, so $p(x)$ had degree 6. The coefficient 5 will remain, so the leading term of $p(x)$ is $5x^6$.

The exponent of each factor is called the *multiplicity* of that zero. In the example above, we would say that $x = -2$ has multiplicity 2, $x = 3$ has multiplicity 3, and $x = 5$ has multiplicity 1. Multiplicity also plays a large role in determining what the graph of a polynomial looks like.

Q3. Let $f(x) = -2(x - 1)^4(x - 2)^2(x - 3)$. List the zeros of $f(x)$, along with their multiplicity. What is the leading term of $f(x)$?

CONCAVITY

Concavity is a general property of functions, of which polynomials serve an excellent example. Intuitively, concavity tells us how the graph of a function bends. If it ‘bends upward’ (a ‘U’ shape), we say it is concave up. If it ‘bends downward’ (an upside down ‘U’ shape), we say it is concave down. As with the property of increasing/decreasing, functions can be concave up on parts of their domain, and concave down on others. Consider the following graph of $f(x) = 5x(x - 1)(x + 1)$:

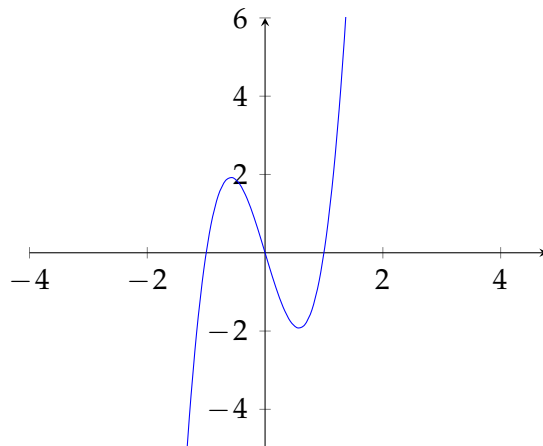

§1.6: POLYNOMIAL FUNCTIONS

It is clear that the left side of the graph is concave down, while the right side of the graph is concave up, which means the graph *changes concavity* (changes the way it bends) somewhere around $x = 0$. Finding the exact points where graphs change concavity is a big question explored in Calculus classes.

Q4. State whether the following families of functions are concave up or concave down.

1. Exponential Growth
2. Exponential Decay
3. Logarithmic Functions
4. Quadratics (note: your answer should depend on a property of the quadratic in question)

§1.7: RATIONAL FUNCTIONS

Rational functions are similar to polynomials, with the exception that unlike polynomials, they may have *vertical and horizontal asymptotes*.

VERTICAL/HORIZONTAL ASYMPTOTES

Horizontal asymptotes describe the *long run* behavior of a function; that is, what happens as the input gets very large (goes to ∞) and very small (goes to $-\infty$). If the y -values approach some finite number c eventually, we say that the horizontal line $y = c$ is a *horizontal asymptote*. For example, the graph

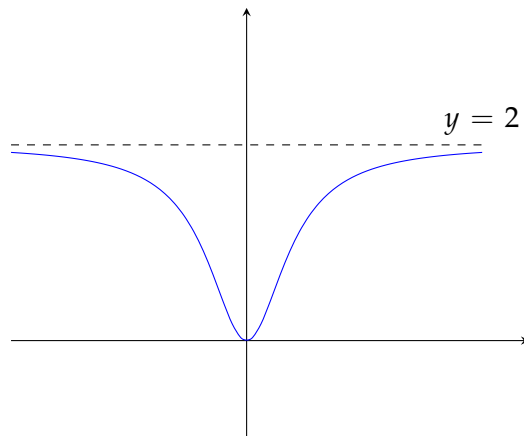

has a horizontal asymptote at $y = 2$.

Vertical asymptotes describe *short run* behavior of a function; that is, what happens as the input gets closer and closer to some finite number c . If the y -values approach $\pm\infty$ as the x -values get closer and closer to $x = c$, we say that the vertical line $x = c$ is a *vertical asymptote*. For example, the graph

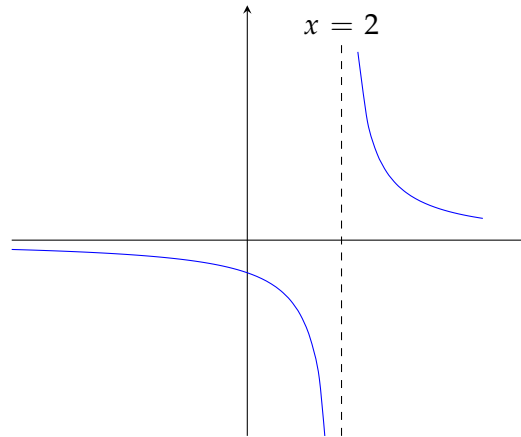

has a vertical asymptote at $x = 2$.

Q1. Sketch a graph that has a vertical asymptote at $x = -1$, and a horizontal asymptote at $y = 0$.

ZEROS AND ASYMPTOTES OF RATIONAL FUNCTIONS

Definition. A *rational function* $r(x)$ is a quotient of polynomial functions; that is, $r(x)$ has the form

$$r(x) = \frac{p(x)}{q(x)},$$

where $p(x)$ and $q(x)$ are polynomials.

For example, $r(x) = \frac{3x^2+2x+1}{x^2+3}$ is a rational function in standard form. In order to know what a rational function's graph looks like, we'll be interested in determining its *zeros*, *horizontal asymptotes*, and *vertical asymptotes*. To determine this information, we'll need to rewrite rational functions in factored form. Specifically, if $r(x) = \frac{p(x)}{q(x)}$,

1. The *zeros* of $r(x)$ come from the zeros of $p(x)$
2. The *vertical asymptotes* of $r(x)$ come from the zeros of $q(x)$

3. The *horizontal asymptotes* of $r(x)$ come from the ratio of the leading terms of $p(x)$ and $q(x)$.

Example. Let's determine this information for the rational function $r(x) = \frac{x^2+2x+1}{x^2-4}$. First, we re-write $r(x)$ in factored form:

$$r(x) = \frac{x^2 + 2x + 1}{x^2 - 4} = \frac{(x + 1)^2}{(x + 2)(x - 2)}.$$

Then we see that $r(x)$ has a zero at $x = -1$ (since this is the only zero of the numerator) and vertical asymptotes at $x = -2$ and $x = 2$ (since these are the zeros of the denominator). Further, since $\frac{x^2}{x^2} = 1$, $r(x)$ has a horizontal asymptote of $y = 1$. We can use a graphing utility to verify that the graph of $r(x)$ looks as follows:

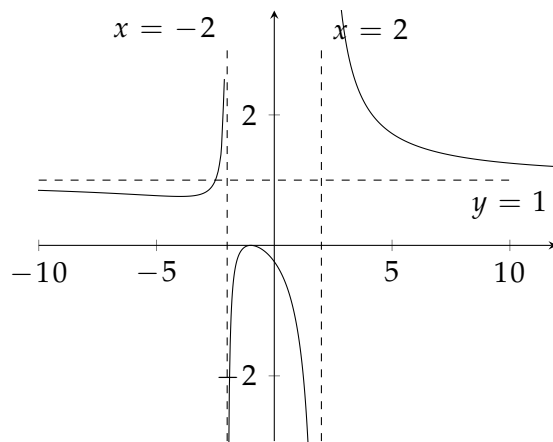

Q2. Find the zeros, vertical asymptotes, and horizontal asymptotes of the rational function

$$r(x) = \frac{2(x + 1)(x - 1)}{(x + 2)(x - 3)}.$$

APPENDIX

A

GROUP WORK

GROUP WORK

§0.1

Simplify the following expressions:

1. $\frac{1}{6} + \frac{3}{4}$

2. $\frac{3^5}{3^7}$

3. $(x^2y^3)^2$

4. $\sqrt{x} \cdot x$

5. $xy \cdot x^2y^{-1}$

6. $(x - 1)^2$

On the graph below, plot and label the points $(1, .5)$ and $(-1, .5)$.

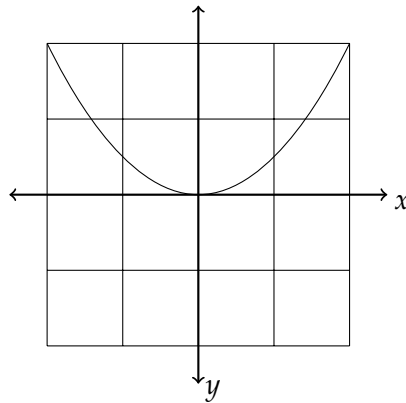

Using the same graph, when x is 2, what is y ? When y is 2, what is x ?

GROUP WORK

Solve for x:

1. $x + 6 = 8$

2. $2x - 4 = 12$

3. $11x - 4 = x + 1$

4. $x^2 + 3 = 19$

5. $\frac{3}{x} = \frac{x}{3}$

6. $x^2 + 7x + 12 = 0$

§0.2

1. Determine whether the following relationships represent functions. You may simply write 'Yes' or 'No', but you should be able to explain your reasoning.

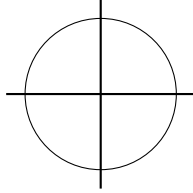

a)

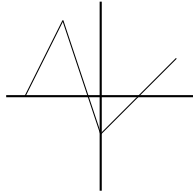

b)

x	y
0	4
1	3
2	0
3	1

c)

x	y
0	4
1	3
1	0
3	1

d)

- e) A ball is thrown in the air. Time (in seconds) after the ball is thrown in the air is the input, and the height of the ball (in feet) above the ground is the output.
- f) A ball is thrown in the air. The height of the ball (in feet) above the ground is the input, and the time (in seconds) after the ball is thrown in the air is the output.

2. Consider the function given by the formula $y = -x^2 + 2$.

a) Write the formula using function notation.

b) Find $f(2)$.

c) Find all x such that $f(x) = 1$.

3. Find the domain of each of the the following functions.

a) $f(x) = \frac{2x}{x-3}$

b) $f(x) = \frac{x^2+2}{5}$

c) $f(x) = \sqrt{x-2}$

d) $f(x) = \sqrt[3]{x-4}$

e) $f(x) = \frac{2}{x^2-25}$

f) $f(x) = \frac{\sqrt{x-1}}{x-10}$

4. Find the domain and range of the function whose graph is given below.

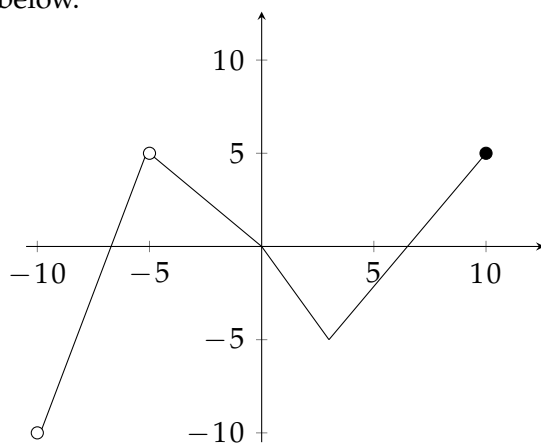

5. Johnny is filling a 12 foot deep swimming pool with water. It takes him 5 minutes to fill the pool. The water level (in feet) of the pool is a function of time (in seconds). What is the domain and range of this function?

§0.3

1. Determine whether the following functions are invertible. You may simply write 'Yes' or 'No', but you should be able to explain your reasoning.

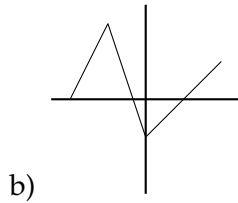
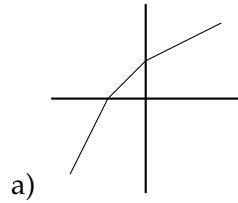

c)

x	y
0	4
1	3
2	0
3	1

d)

x	y
0	4
1	3
2	4
3	1

2. Use the table below to answer the following questions.

x	$f(x)$
0	4
1	3
2	0
3	1

a) $f(0) =$

b) $f(3) =$

c) Find x such that $f(x) = 4$.

d) $f^{-1}(4) =$

e) $f^{-1}(3) =$

f) $f^{-1}(0) =$

3. The functions below are invertible. Find the formula of their inverse function.

a) $f(x) = 4x - 5$

b) $g(x) = \sqrt[3]{x - 2}$

c) $h(x) = x^3 - 5$

4. Suppose $d(t) = t^2$ gives a runner's distance from the starting line t minutes after he started running, and $H(d) = \sqrt{d + 2500}$ gives the runner's heart rate when he is d feet from the starting line. Find a formula for the function that gives the runner's heart rate t minutes after he started running.

GROUP WORK

5. Let $f(x) = \frac{1}{2}x^3$ and $g(x) = \sqrt[3]{2x}$.

a) Find $f(g(x))$.

b) Find $g(f(x))$.

c) Are $f(x)$ and $g(x)$ inverse functions? Explain.

6. Let $f(x) = x^2$ and $g(x) = \sqrt{x}$.

a) Find $f(g(x))$.

b) Find $g(f(x))$. (Be careful!)

c) Are $f(x)$ and $g(x)$ inverse functions? Explain.

§0.4

1. Let $f(x)$ be the function whose graph is as follows:

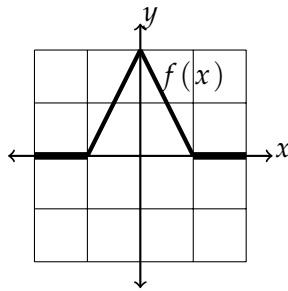

Using the graph of $f(x)$ above, graph the following transformations of $f(x)$:

a) $f(x) + 2$

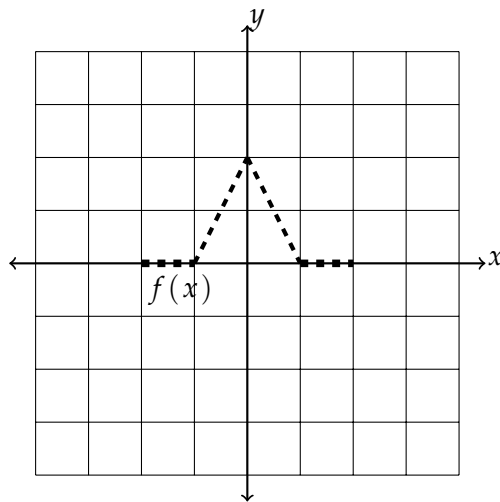

b) $f(x + 2)$

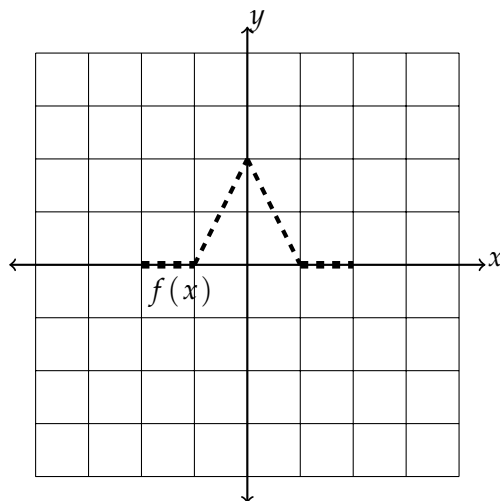

GROUP WORK

c) $-2f(x)$

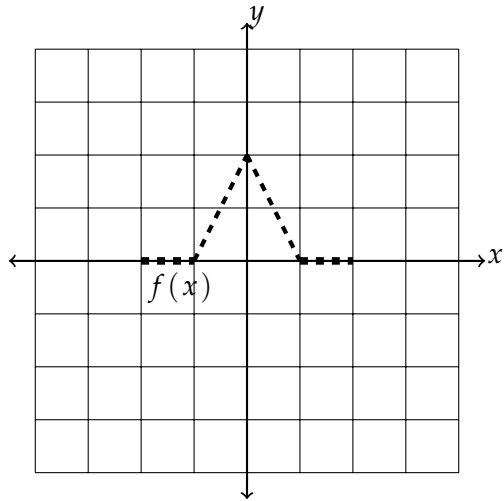

d) $-\frac{1}{2}f(x-2)$

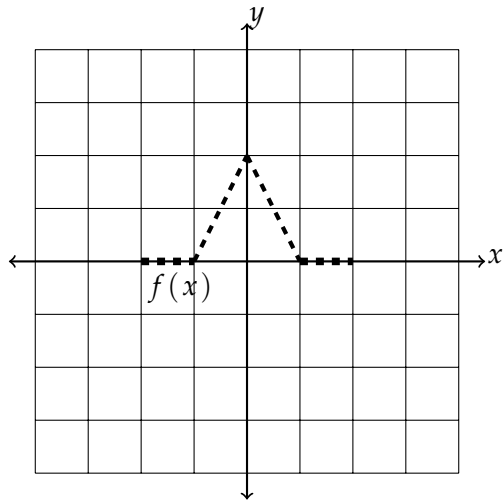

e) $-f(x+2) - 2$

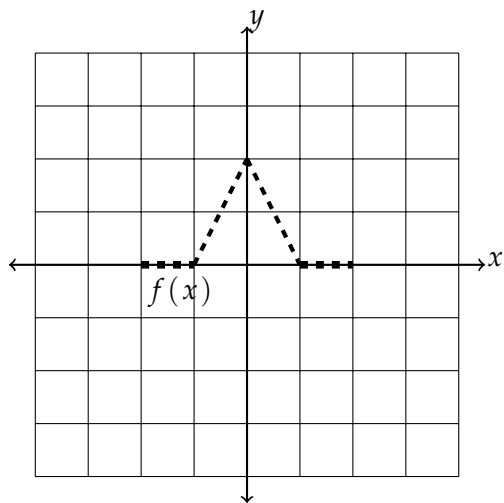

f) $f(-x + 2)$

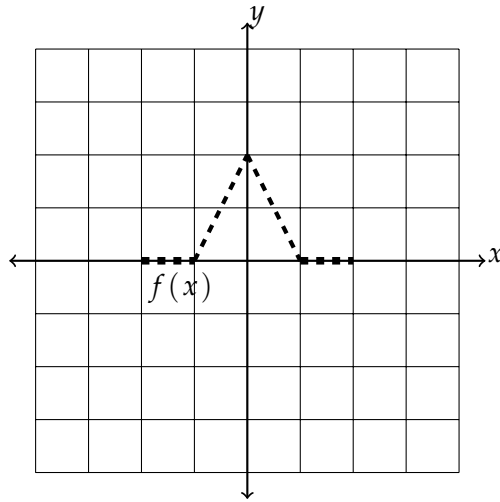

2. Recall that $g(x) = x^2$ is a parabola facing up whose vertex is at the origin:

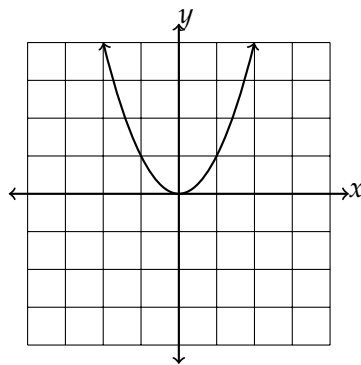

Find a formula for the following graphs of transformations of x^2 :

a)

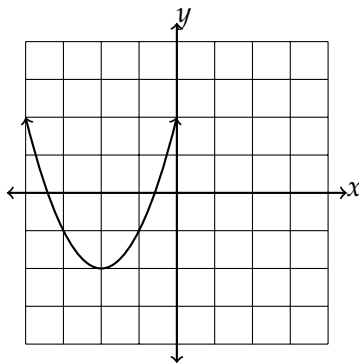

GROUP WORK

b)

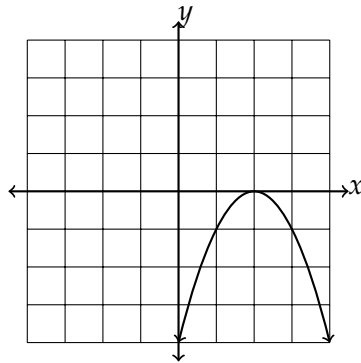

c)

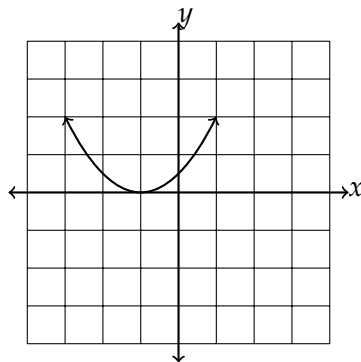

3. Erin is running a newspaper business, and her profit P , as a function of the number of newspapers x she sells, is given by

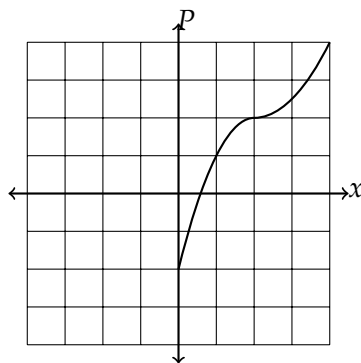

where each unit increase on the x -axis is 10 newspapers, and each unit increase on the P -axis is \$20.

For each scenario below, write the appropriate transformation of $P(x)$ in function notation, and sketch its graph.

- a) Erin finds a way to eliminate her initial costs, so now if she sells 0 papers, her profit is \$0.

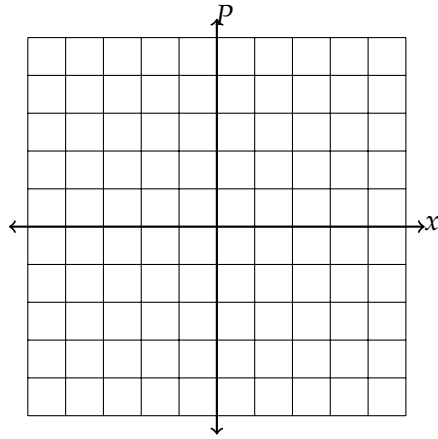

- b) Erin decides to create a promotional deal in which she gives 10 newspapers away for free.

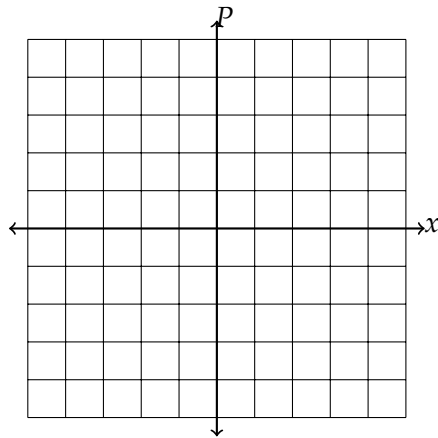

GROUP WORK

§1.1

1. Find the equation of the line passing through the points $(1, 2)$ and $(5, 10)$. Write the equation of the line in both point-slope and slope-intercept form.

2. On the coordinate system below, sketch and label the following lines (your lines need only be accurate with respect to one another).

$$(i) y = 2 \quad (ii) y = 2x \quad (iii) y = 2x + 3$$
$$(iv) y = -2x \quad (v) y = 4x \quad (vi) y = -4x$$

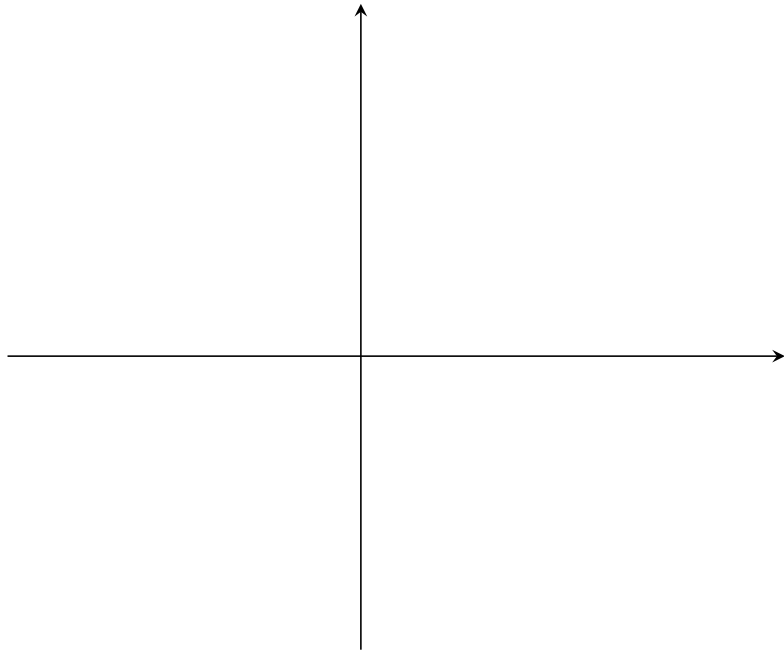

3. A race car is driving around the track, and you would like to come up with a function which tells you how many feet the car has driven t seconds after it started driving. You time how long it takes the car to complete a lap for the first 4 laps. Given that 1 lap is 5,000 feet, you come up with the following data points:

t (sec)	$d(t)$ (ft)
0	0
50	5,000
100	10,000
150	15,000
200	20,000

- a) Based on your data points, could the function $d(t)$ be linear? Why or why not?
- b) If your answer to (a) was 'yes', what is the slope and y -intercept of your linear function?
- c) Write an equation for $d(t)$ assuming it is linear.
- d) How far has the car traveled after 70 seconds?
- e) How long does it take the car to travel 12,000 feet?

GROUP WORK

4. You have a blue cup of water at room temperature (67°F), and you begin heating the blue cup at a constant rate of 5°F per minute. You also have a red cup of ice (so it is 32°F), and you begin heating the red cup at a constant rate of 10°F per minute.
- Write a function that describes the temperature of the water in the blue cup t minutes after you started heating it.
 - Write a function that describes the temperature of the water in the red cup t minutes after you started heating it.
 - When will the water in the blue cup and the water in the red cup be the same temperature? What is this temperature?

5. You have a lemonade stand, and you'd like to come up with a function that tells you your profit if you sell x cups of lemonade. The table for your stand costs you \$50, and you make \$2 for each cup that you sell.
- Write a function that tells you your profit after selling x cups of lemonade.
 - Find the inverse function of your function from (a). What are the units of the input for the inverse function? What are the units of the output for the inverse function?
 - If you want to make \$100 in profit, how many cups of lemonade must you sell?

Position, Velocity, and Acceleration

A skydiver jumps out of a plane, and his position s (in meters) away from the airplane after t seconds is given in the following table:

t	s
0	0
2	19.6
4	78.4
6	176.4
8	313.6
10	490

1. What does a rate of change between t values in this table represent? Include units.
2. Calculate the rates of change between each consecutive interval to fill in estimates for the following table:

t	v
1	
3	
5	
7	
9	

3. What does a rate of change between t values in this table represent? Include units.
4. Calculate the rates of change between each consecutive interval to fill in estimates for the following table:

t	a
2	
4	
6	
8	

GROUP WORK

5. Graph and label the three tables on the coordinate axes below:

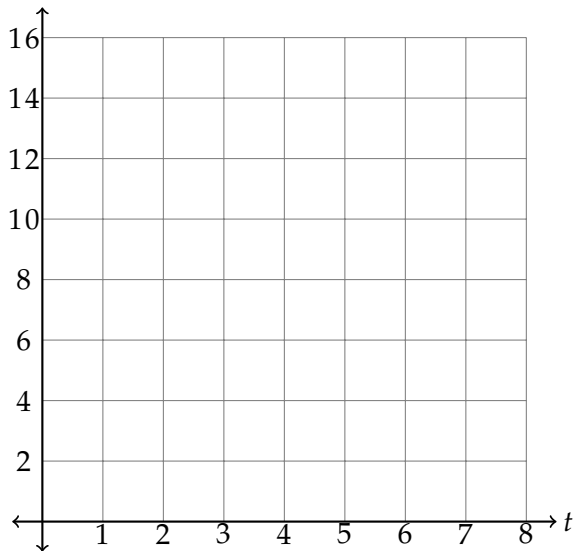
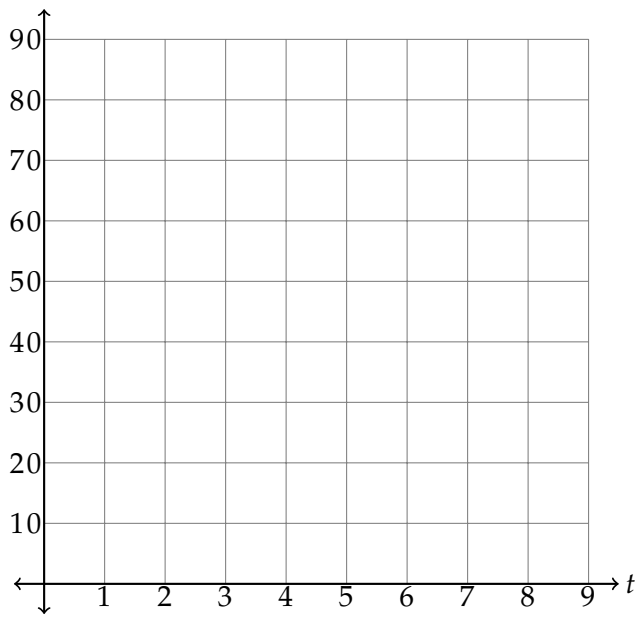
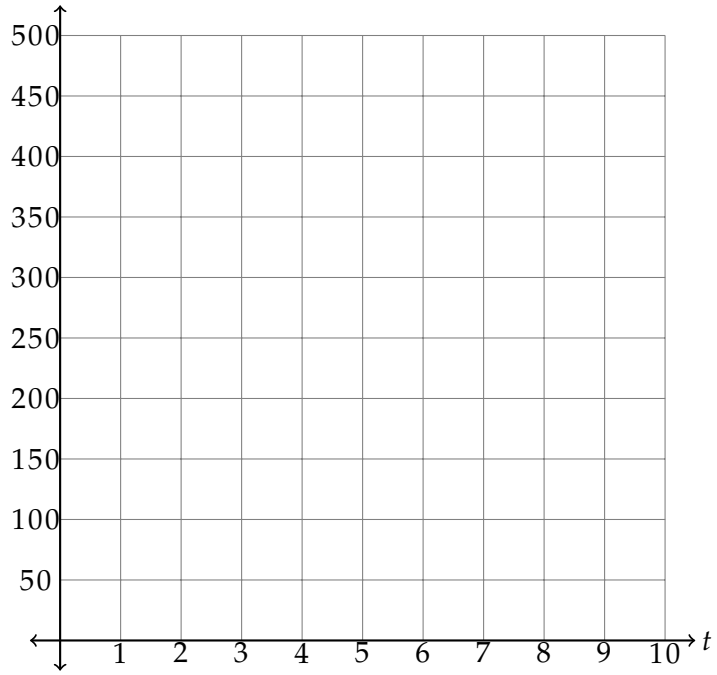

6. Find the equation for the graph of the table from part 2.

7. Use your equation to answer the following:

a) How fast is the skydiver going after 20 seconds?

b) When is the skydiver traveling 150 meters per second?

GROUP WORK

§1.2

1. Re-write the following quadratic functions in *factored form*.

a) $f(x) = x^2 + 6x - 7$

b) $f(x) = x^2 - x - 6$

c) $f(x) = x^2 - 8x + 15$

d) $f(x) = 2x^2 + 8x + 8$

2. Re-write the following quadratic functions in *vertex form*, then list the vertex of the parabola.

a) $f(x) = x^2 - 4x + 9$

b) $f(x) = 2x^2 + 12x + 16$

3. A ball is thrown in the air from the top of a building, and the height (in feet) of the ball after t seconds is given by the function $h(t) = -t^2 + 10t + 25$.

a) How tall is the building?

b) When does the ball reach its maximum height, and what is the maximum height?

c) When does the ball hit the ground?

GROUP WORK

4. Solve the following inequalities.

a) $x^2 + 3x + 2 > 0$

b) $x^2 - 6x + 8 < 0$

c) $x^2 + 3x - 4 \geq 0$

d) $x^2 + 2x + 1 > 0$

5. Use the quadratic formula to find the zeros of the following quadratics. If a quadratic has no zeros, say so.

a) $f(x) = x^2 + 4x + 2$

b) $f(x) = x^2 - 6x + 9$

c) $f(x) = 2x^2 - 8x + 11$

GROUP WORK

§1.3

1. Determine whether the following describe linear or exponential relationships, then write an equation for the function that models them.
 - a) You invest \$100 in a bank account that is growing by \$15 per month.

 - b) You invest \$100 in a bank account that is growing by 15% per month.

 - c) The value of a \$20,000 new car depreciates by \$500 per year.

 - d) The value of a \$20,000 new car depreciates by 20% per year.

2. The population of an ant colony is initially 100 ants, and grows at a rate of 10% every 2 years.
 - a) Write a function which gives the population of the ant colony after t years.

 - b) By what percentage does the ant colony grow each year? (Hint: this is the growth rate)

3. You take 100 mg of aspirin, which your body decomposes 15% in 3 hours.
- Write a function which gives the amount of aspirin in your body t hours after you took it.
 - What percentage of the aspirin does your body decompose in 1 hour? (Hint: this is the decay rate)
4. You have a \$200 balance on your credit card. Taking interest into account, the amount you owe after t months on your credit card (assuming you don't make any payments) is given by

$$A(t) = 200e^{.2t}.$$

- What is the continuous growth rate of this function?
- What is the monthly interest you are charged (as a percent)? (Hint: this is the growth rate)

GROUP WORK

5. Find the equation of the exponential function whose y -intercept is 3 and passes through the point $(3, 24)$.

6. Find the equation of the exponential function passing through the points $(-2, 16)$ and $(4, \frac{1}{4})$.

§1.4

1. Simplify the following logarithms.

a) $\log\left(\frac{x}{yz}\right)$

b) $\log(x^2)$

c) $\log(10x^2)$

2. A population increases by 13% each year.

a) Write a function that gives the population after year t , assuming the initial population is some constant P_0 .

b) Find the doubling time of the population.

c) Find the continuous growth rate of the population.

§1.5

- Recall from our reading assignment that given the picture

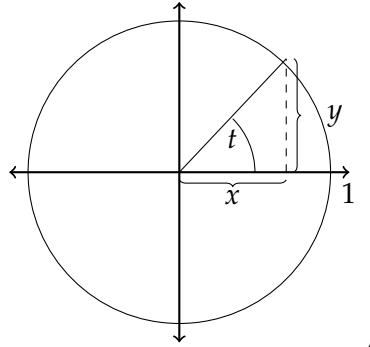

we define $\sin(t) = y$ and $\cos(t) = x$. For any angle t , what can you say about $\sin^2(t) + \cos^2(t)$? (Hint: Use the Pythagorean Theorem)

- We also know from our reading assignment that $\sin(x)$ is odd and $\cos(x)$ is even. Use this to complete the following identities for these trig functions:

$$\sin(-x) =$$

$$\cos(-x) =$$

- Solve the following for x .

- $6 \sin(x) - 4 = 2$

- $2 \cos(x) + 1 = -1$

GROUP WORK

c) $3 \tan(x) + 2 = 2$

4. The goal of this exercise is to think about what transformations (section 0.4) of trigonometric functions look like. Refer to your reading assignment to help you remember what the graphs of $\sin(x)$ and $\cos(x)$ look like.

a) Use your knowledge of transformations to complete the following identities:

$$\sin\left(x + \frac{\pi}{2}\right) =$$

$$\cos\left(x - \frac{\pi}{2}\right) =$$

b) Give a rough sketch of what $f(x) = \cos(x) + 1$ looks like.

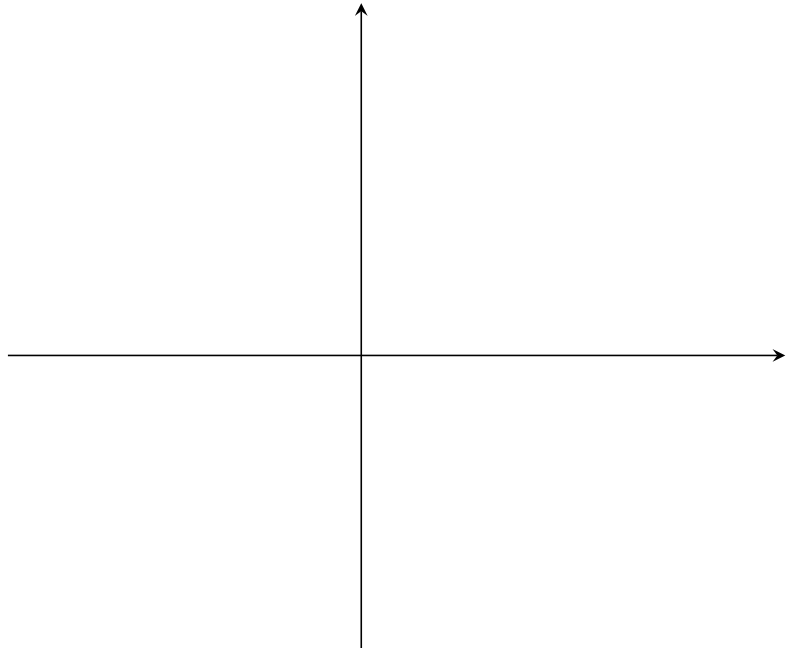

c) Describe in words how the graph of $g(x) = 2 \sin(x)$ compares to the graph of $f(x) = \sin(x)$.

5. Determine whether the functions below are even, odd, or neither.

a) $f(x) = \frac{x^4 - x^2}{x^3 + x}$

b) $g(x) = \sin(x) \cos(x)$

c) $h(x) = \sin(x) + \cos(x)$

d) $k(x) = p(x)(q(x))^2$, where $p(x)$ is even and $q(x)$ is odd.

GROUP WORK

§1.6

1. Sketch the graph of each polynomial below. Label the zeros and y -intercept on your graph.

a) $f(x) = -2(x + 3)(x - 1)(x - 2)$

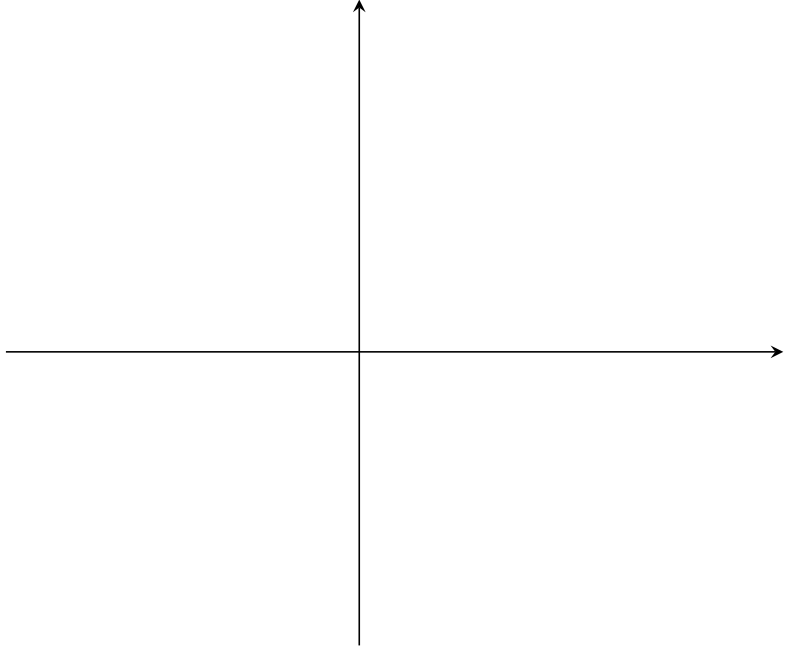

b) $p(x) = 4x^2(x - 2)^2(x + 2)(x - 4)^3$

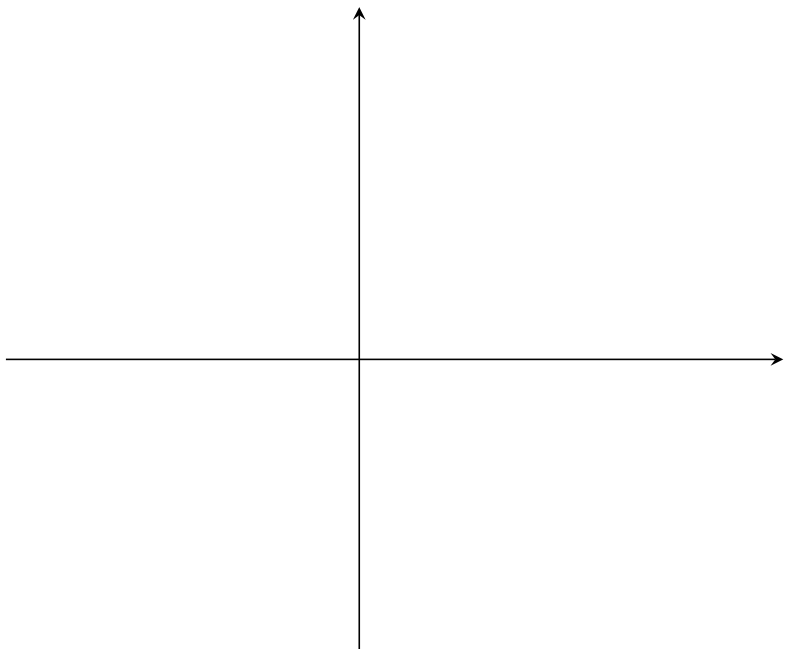

2. For each graph below, find a potential equation of the polynomial.

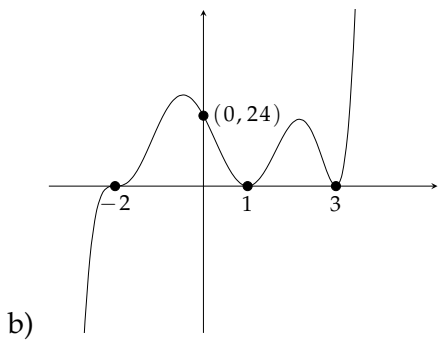
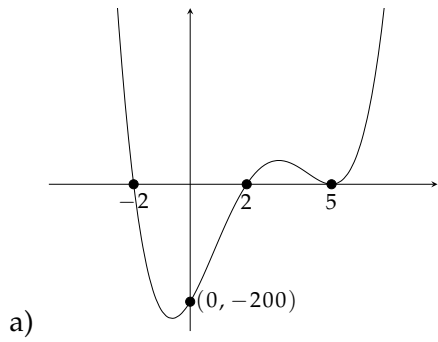

3. On each of your graphs in problems 1 and 2, estimate where the changes in concavity occur, and label each section of your graph as 'concave' up or 'concave down'.

GROUP WORK

§1.7

1. Sketch the graph of each rational function below. Label the zeros, asymptotes, and y -intercept on your graph.

a) $f(x) = \frac{-2(x+2)(x-2)}{x-1}$

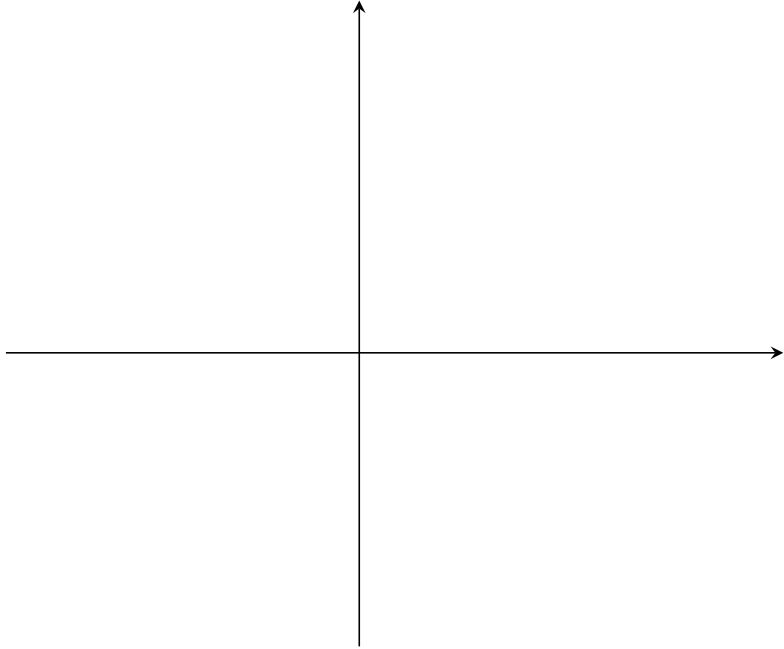

b) $r(x) = \frac{x^2-1}{x^2-4}$

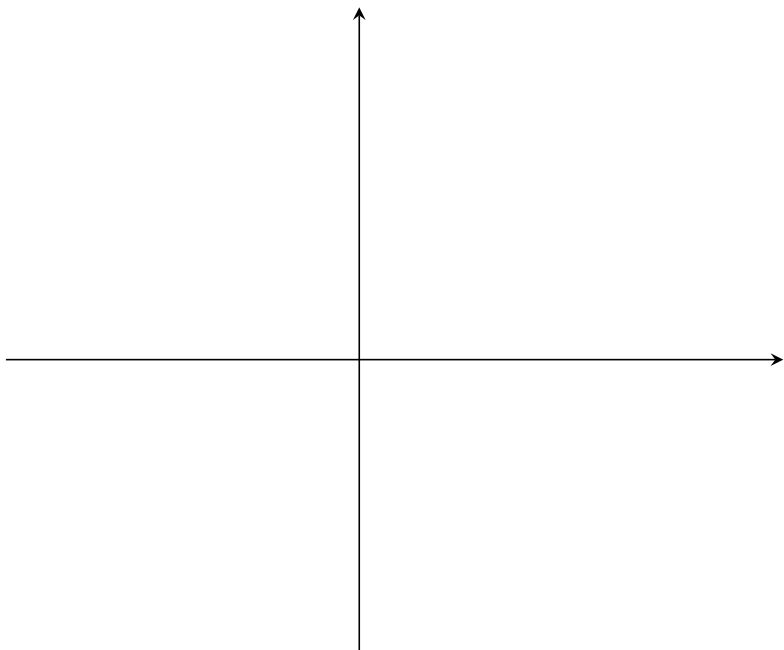

2. For each graph below, find a potential equation for the rational function.

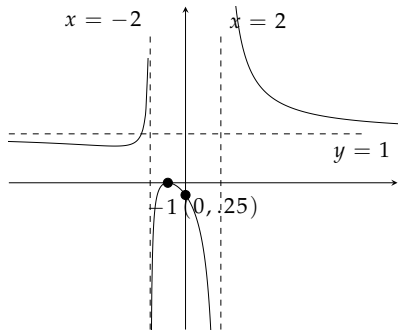

a)

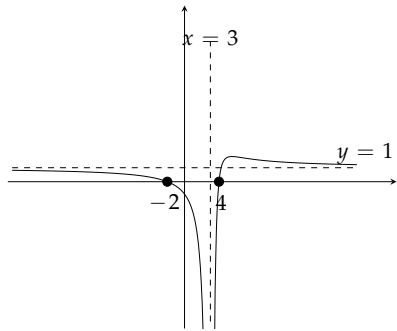

b)

(The y -intercept is $(0, -\frac{8}{9})$.)

B

HOMEWORK

HOMEWORK

§0.2 - §0.3

Show your work on separate paper. Your work should be clear and organized.

1. Consider the function $f(x) = \frac{10}{\sqrt{x+5}}$.
 - a) Find $f(20)$.
 - b) Find x such that $f(x) = 5$.
 - c) Find the domain of $f(x)$.
2. Let $f(x) = 5x^3 + 2$.
 - a) Compute $f^{-1}(x)$.
 - b) Using composition of functions, verify that your answer in (a) is truly the inverse function of $f(x)$.
3. Let $f(x) = \sqrt{x^2 + 2}$. Find functions $g(x)$ and $h(x)$ such that $f(x) = g(h(x))$.

§0.4 - §1.1

Show your work on separate paper. Your work should be clear and organized.

1. Let $g(x) = \sqrt{x}$.
 - a) Use a graphing utility to sketch a graph of $g(x)$.
 - b) Without a graphing utility, sketch $g(x + 2) + 2$.
 - c) Without a graphing utility, sketch $-g(-x)$.
 - d) Write a formula for the function whose graph is the following transformation of $g(x)$: Shifted horizontally 1 unit right, reflected vertically, and stretched vertically by 3 units
2. Write an equation of the line which passes through the points $(-4, 5)$ and $(6, 0)$. What is the y -intercept of this line?
3. Let $p(x) = x^3 - 4x^2 - 3x + 18$.
 - a) Use a graphing utility to sketch a graph of $p(x)$.
 - b) On what interval(s) is $p(x)$ increasing? On what interval(s) is $p(x)$ decreasing?

HOMEWORK

§1.1 - §1.2

Show your work on separate paper. Your work should be clear and organized.

1. A taxi service charges a \$10 flat fee, plus \$5 per mile driven.
 - a) Write a formula for the amount of money you owe as a function of the number of miles you were driven.
 - b) Using your formula from (a), how much will you owe if you take the taxi 10 miles to the airport?
 - c) If you only have \$100 to spend, what is the furthest distance the taxi can take you?
2. At which x value(s) do the functions $f(x) = x^2$ and $g(x) = 2x + 3$ intersect?
3. Find the vertex of the parabola whose equation is

$$y = x^2 - 4x + 7.$$

§1.2 - §1.3

Show your work on separate paper. Your work should be clear and organized.

1. You shoot a bottle rocket whose trajectory follows the path $h(t) = -t^2 + 8t + 84$, where $h(t)$ is the height of the rocket in feet above the ground at time t seconds.
 - a) When you fire the rocket (time $t = 0$), are you standing on the ground? If not, how high above ground are you?
 - b) What is the maximum height above the ground that the rocket reaches?
 - c) How long does it take for the rocket to hit the ground?
2. Find the equation of the exponential function passing through the points $(-1, \frac{1}{12})$ and $(2, 18)$.
3. Suppose a cluster of weeds grows exponentially if left unattended, and the number of weeds double every 10 days.
 - a) If the cluster starts with 20 weeds, write a formula for the number of weeds in the cluster after t days.
 - b) By what percentage does the cluster increase after a single day?

HOMEWORK

§1.4 - §1.5

Show your work on separate paper. Your work should be clear and organized.

1. An 100 in^3 ice cube melts according to the formula $A(t) = 100(.9)^t$, where $A(t)$ is the volume of ice left after t minutes.
 - a) What is the half-life of the cube of ice?
 - b) What is the continuous decay rate?
2. Determine whether the following functions are odd, even, or neither.
 - a) $f(x) = \sqrt{x^2 - 2}$
 - b) $g(x) = \frac{\sqrt{x^2 - 2}}{x^3}$
 - c) $h(x) = k(x) + j(x)$, where $k(x)$ is even and $j(x)$ is odd

§1.6

Show your work on separate paper. Your work should be clear and organized.

1. Sketch the graph of the polynomial

$$p(x) = -3(x + 4)(x - 1)^3(x - 2)^2.$$

Label the zeros and y -intercept of your graph.

2. Sketch a graph of a polynomial with the following characteristics. Then provide a possible formula for the polynomial.
 - y -values approach $-\infty$ as x approaches $\pm\infty$
 - Zeros at $x = -2$ (multiplicity of 3), $x = 3$ (multiplicity of 2), and $x = 5$ (multiplicity of 1)
 - y -intercept of $(0, 36)$

HOMEWORK

§1.7

Show your work on separate paper. Your work should be clear and organized.

1. Sketch the graph of the rational function

$$r(x) = \frac{(x+2)(x-2)}{(x+1)^2}.$$

Label the zeros, horizontal/vertical asymptotes, and y -intercept of your graph.

2. Sketch a graph of a rational function with the following characteristics. Then provide a possible formula for the rational function.
 - Horizontal asymptote of $y = 2$
 - y -intercept is negative
 - Zero at $x = 1$ (with multiplicity of 2)
 - Vertical asymptotes at $x = -1$ and $x = 2$

C

QUIZZES

QUIZZES

QUIZ 1 (§0.2 - §0.4)

1. Let $f(x) = \frac{2}{2x-4}$.

a) (1 point.) Find $f(4)$.

b) (2 points.) Solve $f(x) = 1$.

c) (2 points.) Find the domain of $f(x)$.

2. (2 points.) Let $g(x) = (x - 2)^3 + 1$. Find $g^{-1}(x)$.

3. (2 points.) Let $f(x) = x^2 + x + 1$ and $g(x) = \sqrt{x}$. Compute $f(g(x))$.

4. (1 point.) Let $h(x) = x^2$. Circle the graph below which corresponds to $-h(x + 5)$.

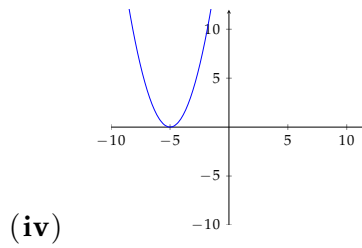
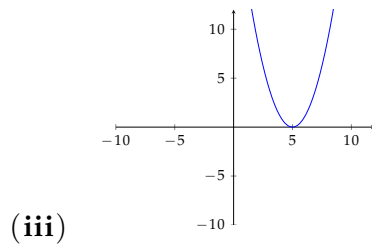
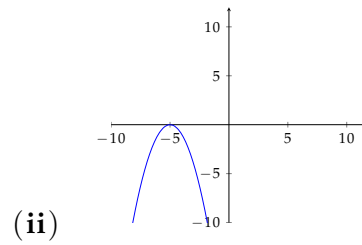
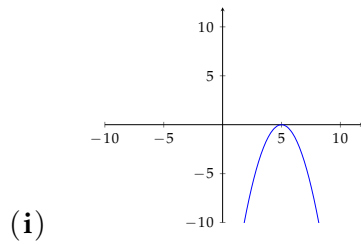

QUIZZES

QUIZ 2 (§1.1 - §1.2)

1. (3 points.)

a) Calculate the rate of change between the points $(-2, 3)$ and $(2, -1)$.

b) Write the equation of the line connecting these two points.
(Hint: Using point-slope form is easiest)

c) Find the y -intercept of your line from part (b).

2. (2 points.) At what point do the lines $y = 2x + 3$ and $y = -3x + 13$ intersect?

3. (3 points.) Let $f(x) = x^2 + 10x + 21$.
- a) What is the y -intercept of $f(x)$?

b) What is the vertex of $f(x)$?

c) What are the zeros of $f(x)$?

4. (2 points.) Solve the following inequality:

$$x^2 + 2x - 3 \leq 0.$$

QUIZZES

QUIZ 3 (§1.4 - §1.6)

1. (1 point.) Simplify the following logarithm:

$$\log \left(\frac{x^2 y^3}{z} \right)$$

2. (2 points.) Find the doubling time of a population which grows 25% every year.

3. (1 point.) Solve $\cos(x) + 1 = 2$ for x .

4. (3 points.) Let $f(x) = 4 \sin(2x) + 3$.

a) What is the amplitude?

b) What is the period?

c) What is the vertical shift?

5. (3 points.) Sketch the long run behavior of the following polynomials:

a) $p(x) = 6x^4 + 3x^2 + 2x + 3$

b) $q(x) = 5x^5 + 3x^3 + 4$

c) $r(x) = -3(x + 3)^2(x - 1)^3(x - 2)$

QUIZZES

QUIZ 4 (§1.6 - §1.7)

1. Sketch $p(x) = -2(x - 2)^3(x + 1)(x - 1)^2$.

2. Find a possible formula for the graph

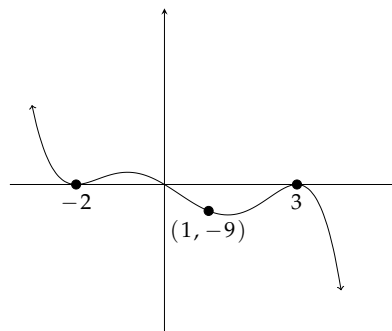

3. Sketch the graph of the rational function

$$r(x) = \frac{(x + 2)(x - 2)}{(x + 1)^2}.$$

Label the zeros, horizontal/vertical asymptotes, and y -intercept of your graph.

4. Sketch a graph of a rational function with the following characteristics. Then provide a possible formula for the rational function.
- Horizontal asymptote of $y = 2$
 - y -intercept is negative
 - Zero at $x = 1$ (with multiplicity of 2)
 - Vertical asymptotes at $x = -1$ and $x = 2$

D

EXAMS

EXAMS

DIAGNOSTIC EXAM

Simplify the following expressions:

1. $\frac{5}{8} + \frac{2}{3}$

2. $\frac{2^5}{2^3} + 3^2 3^{-1}$

3. $\left(\frac{x^3 y^6}{x^5 y^4}\right)^2$

4. $\sqrt{x} \cdot \sqrt{x^5}$

5. $\frac{10x}{\frac{5}{x}}$

6. $(2x + 4)^2$

On the coordinate system below, plot and label the points $(1, 2)$, $(-2, 1)$, $(-1, -1)$, and $(2, -1)$.

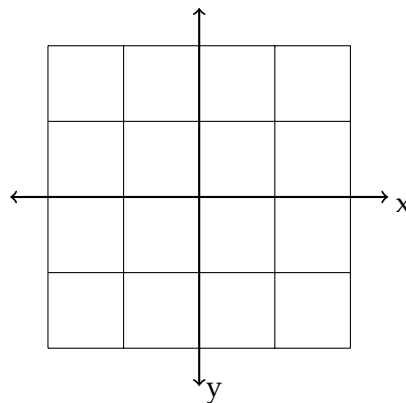

Solve for x :

1. $x + 5 = 2$

2. $3x - 9 = 15$

3. $5x - 4 = 2x + 5$

4. $x^2 - 3 = 1$

5. $\frac{5}{x} = \frac{x}{5}$

6. $x^2 - 3x + 2 = 0$

Complete the following tables using the given information:

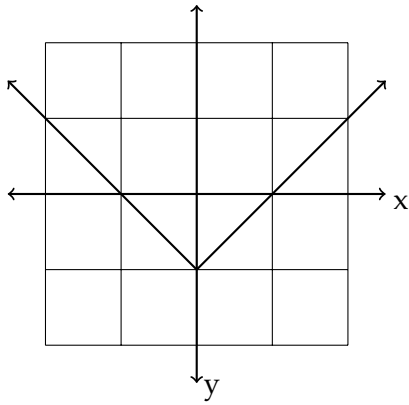

x	-1	1	2	
y				-1

$$z = -x^2 + 1$$

x	0	1	2	
z				-8

MIDTERM EXAM

1. (4 points.) Circle the relationships which represent functions.

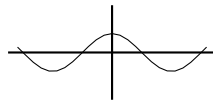

x	y
0	4
1	5
2	4
3	2

Eye color is the input, and students' names with that eye color is the output

$y = 2x + 1$

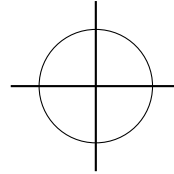

x	y
0	1
2	6
4	5
2	3

2. (4 points.) Circle the functions which are invertible.

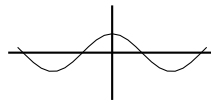

x	y
0	4
1	5
2	4
3	2

Time is the input, and the height of a ball is the output

$y = 2x + 1$

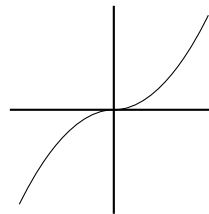

x	y
0	1
1	4
2	6
3	3

3. (4 points.) Find the domain of $f(x) = \frac{5}{\sqrt{5x+10}}$.

4. (12 points.) Let $f(x)$ be given by the following graph:

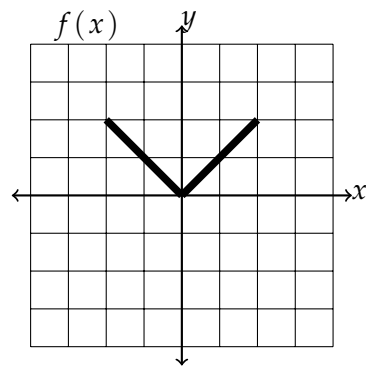

Sketch the following transformations of $f(x)$:

a) $f(x - 1)$

c) $2f(x + 1)$

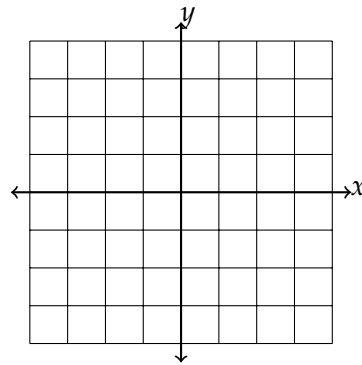
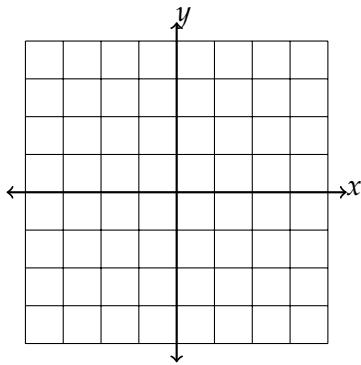

b) $-f(x)$

d) $-f(-x + 1) + 1$

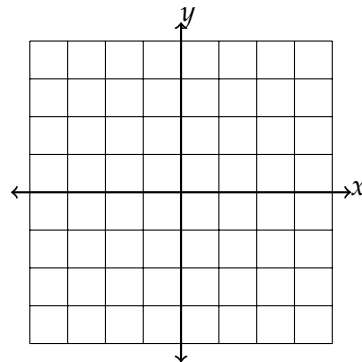
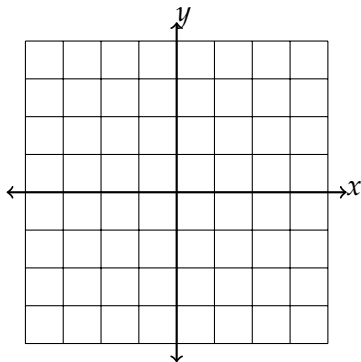

EXAMS

5. (12 points.) Consider the points $(-2, 1)$ and $(3, 11)$.
- Calculate the rate of change between these two points.
 - Write the equation of the line connecting these two points using point-slope form.
 - Write the equation of the line connecting these two points in slope-intercept form.
 - What is the y -intercept of the line?

6. (12 points.) Let $f(x) = x^2 - 10x - 24$.
- What is the y -intercept of $f(x)$?

b) What is the vertex of $f(x)$?

c) What are the zeros of $f(x)$?

7. (10 points.) Find the equation of the exponential function which passes through the points $(2, 8)$ and $(3, 32)$.

8. (12 points.) Let $f(x) = .5^x$ and $g(x) = x - 2$.

a) Compute $f(g(x))$.

b) Sketch a graph of $f(g(x))$.

c) Compute $g(f(x))$.

d) Sketch a graph of $g(f(x))$.

9. (18 points.) You have a bank account and initially invest \$100.
- Write an equation for the amount of money you have in your account as a function of time t years since you invested if you earn \$50 in interest each year.
 - When will you have \$600?
 - Write an equation for the amount of money you have in your account as a function of time t years since you invested if you earn 10% in interest each year.
 - Sketch the graph of your equation from part (c), labeling the y -intercept.

EXAMS

10. (12 points.) A tomato is thrown in the air. Its height (in feet) t seconds after it was thrown is given by

$$h(t) = -t^2 + 4t + 5.$$

- a) When does the tomato hit the ground?

- b) What is the maximum height that the tomato reaches?

FINAL EXAM

1. (10 points.) Are the following simplifications of logarithms correct? If so, leave the expression as is. If not, cross out the expression and correct it.

a) $\log_2(16) = 4$

b) $\log(.1) = 1$

c) $\log(x^2) = 2\log(x)$

d) $\log(10x^2) = 2\log(10x)$

e) $\ln(e^5) = 5$

f) $e^{2\ln(x)} = x$

g) $\log\left(\frac{x^2}{y^3}\right) = 2\log(x) - 3\log(y)$

EXAMS

2. (10 points.) A substance decays 15% each minute.
- Find the half-life of the substance.

- Find the continuous decay rate of the substance.

3. (6 points.) Solve $\sin(x) = -1$.

4. (10 points.) Find a formula for the following trigonometric function:

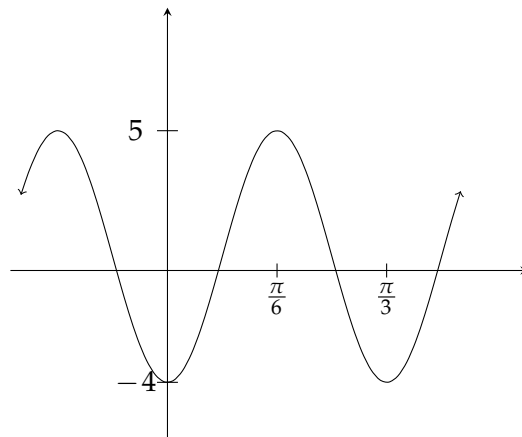

5. (8 points.) Label the following functions as even, odd, or neither.

a)

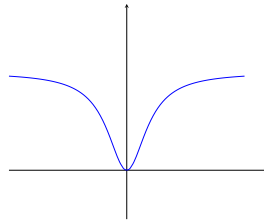

c) $g(x) = x^2 \cos(x)$

b) $f(x) = \sin(x)$

d) $h(x) = x^3 + x + 1$

6. (8 points.) Label the following functions as CCU (concave up) or CCD (concave down).

a)

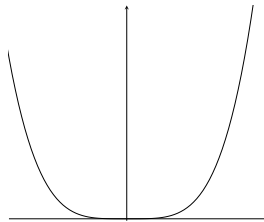

c) $g(x) = 5(.65)^x$

b) $f(x) = \ln(x)$

d) $h(x) = -x^2 + 2x + 1$

7. (12 points.) Graph $f(x) = 3(x + 2)(x - 3)(x - 1)^2$. Label all zeros, the y -intercept, and show work to obtain the long run behavior.

8. (10 points.) Find a possible formula for the following graph:

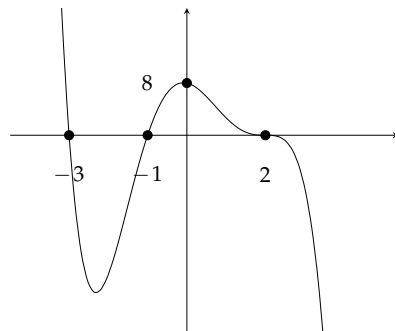

9. (12 points.) Consider the function

$$f(x) = \frac{x^2 - 4}{x^2 - 1}.$$

a) What are the zeros of $f(x)$?

b) List the equation(s) of the vertical asymptote(s).

c) What is the horizontal asymptote?

10. (14 points.) Graph

$$s(x) = \frac{2(x+1)^2(x-3)}{(x+3)(x-1)^2}.$$